



Monitoring Tool for Work Implementation & Funds Utilisation of Various Schemes of Haryana & Centre Government for

- Development & Panchayats Department
- Rural Development Department



Austere System Private Limited
(ASPL)

IndusInd Bank

IndusInd **Bank** Limited

User Manual
For
Funds Disbursement
Management System
(FDMS)

Document Version 1.1

User Manual for Funds Disbursement Management System

Table of Contents

1. Login Screen:.....	4
2. Instalment:	6
2.1. Admin Login:.....	6
2.2. Dashboard View:.....	7
2.3. Map View:	8
2.4. User Creation:.....	10
2.5. Assign Role:.....	11
2.6. Assign Assistant:.....	12
2.7. Input Form:	13
• Chief Executive Officer (CEO) Login:	13
2.8. Assistant Login:.....	14
• Dashboard View:.....	14
• Sanction Form:	15
2.9. Instalment approval workflow with flow charts:.....	16
3. Executive Agency Login:.....	28
3.1. Sanction Works:	28
3.2. Work Details Form:.....	29
3.3. Utilization Certificate:.....	30
3.4. Financial Progress:.....	31
3.5. Child Account Details:	31
4. Physical Monitoring:	32
4.1. Alert Notification Pending:	32
4.2. Inspection Report:	32
5. Through Mobile Application:.....	33
5.1. In JE Login:.....	33
5.2. In SDO Login:	34
5.3. In XEN Login.....	34
6. Utilization Certificate:	35
7. Helpline Numbers:.....	36
7.1. IT Support Team:.....	36
7.2. Bank Representatives:	36

User Manual for Funds Disbursement Management System

1. Login Screen:

- Click on FDMS button for login screen.

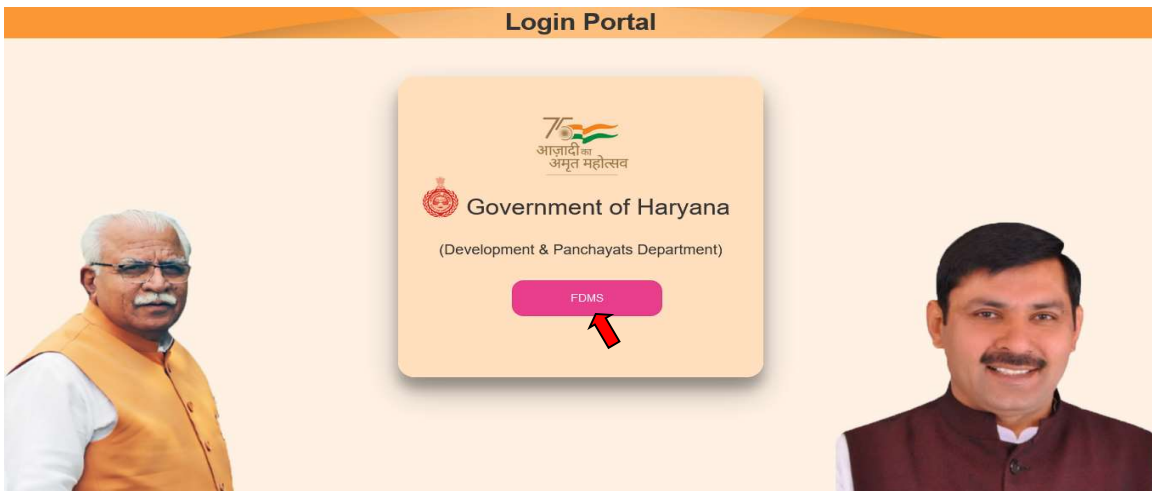

- Select Master Role and Role from dropdown. Enter Email/Mobile number and password for that particular selected role, Also input Captcha for login.

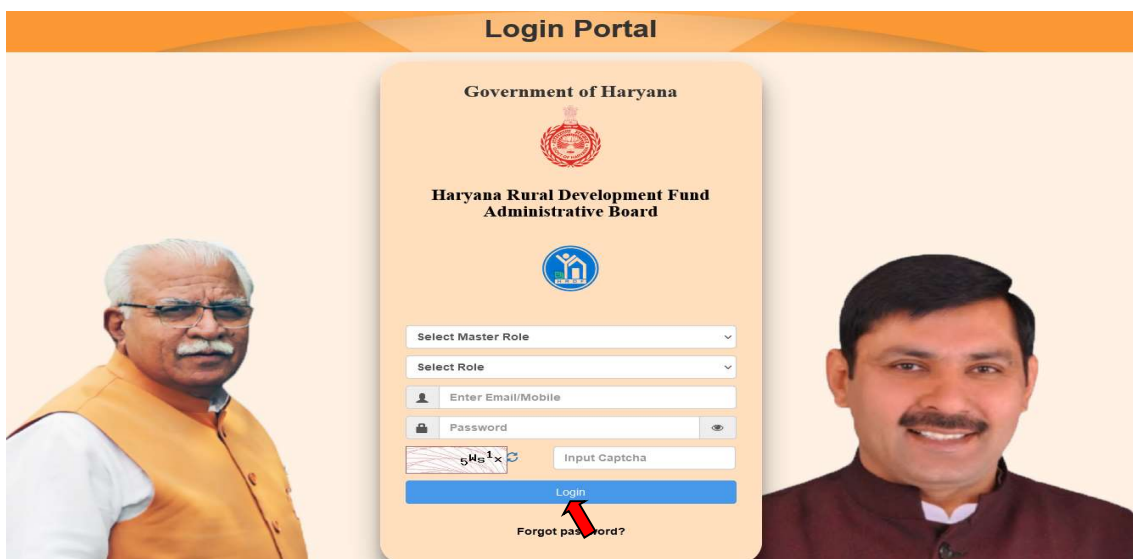

User Manual for Funds Disbursement Management System

- Also, you can reset your password by clicking on Forgot password?

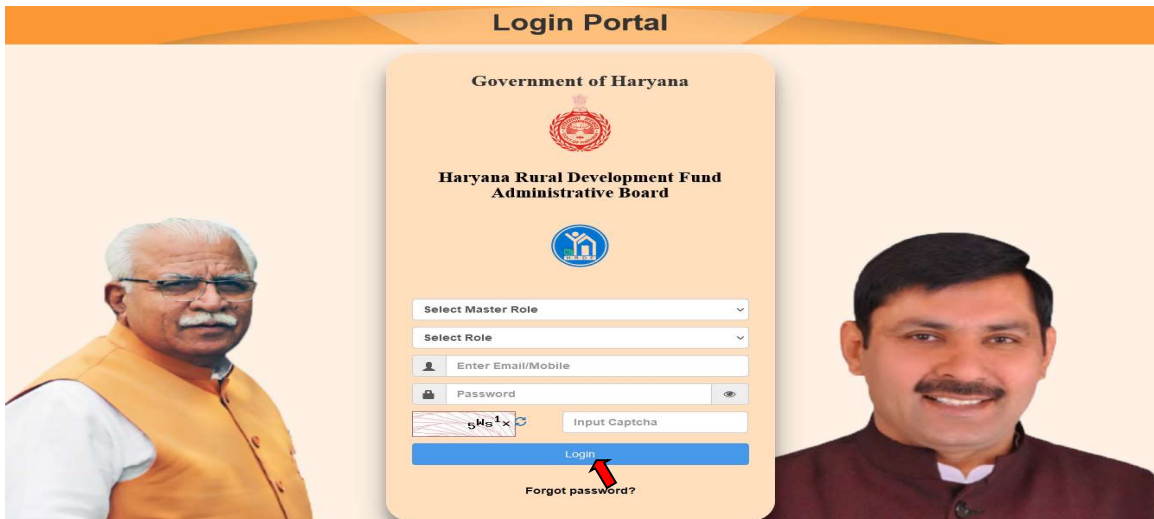

- Enter Phone Number, click on send OTP

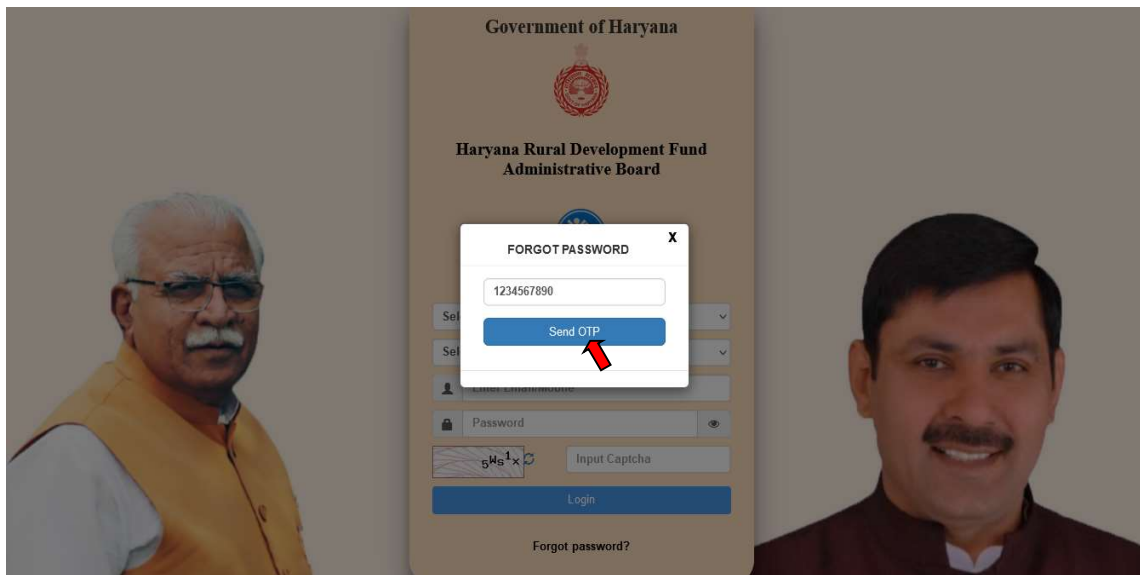

User Manual for Funds Disbursement Management System

2. Instalment:

2.1. Admin Login:

This workflow starts with admin section login by enter the admin details.

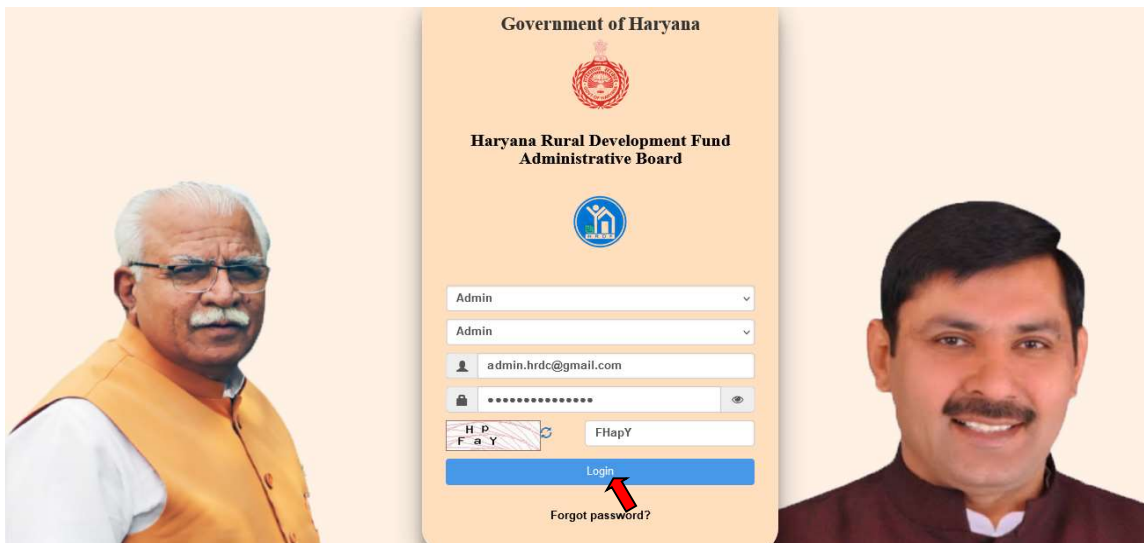

Government of Haryana

Haryana Rural Development Fund
Administrative Board

Admin

Admin

admin.hrdc@gmail.com

H P F a Y

FHapY

Login

Forgot password?

User Manual for Funds Disbursement Management System

2.2. Dashboard View:

Admin Dashboard will open, you can check the status of work by selecting scheme, District, Block and Village from dropdown. Bar charts and Pie charts also show the status of work. Also check the 5 Best and least Performing Districts in the dashboard.

Dept. Of Panchayat

Admin

- 🏠 Dashboards
- 📍 Map
- 👤 User Creation >
- 👤 Child Account Details
- 👤 SNA Account Details
- 👤 Transfers >
- 🚪 Log Out

☰ "Haryana Ek Haryanvi Ek"
👤

Scheme: HRDF SCHEME | District: Select District | Block: Select Block | Village: Select Village

Financial Status

Fund Sanctioned : 31.64 Cr

Fund Released : 1.03 Cr

Nature Of Work

Departmental : 311

Tender : 7

Delays (More Than 3 Months)

Funds Not Utilised : 29.74 Cr

Work Not Started : 2

Work Type

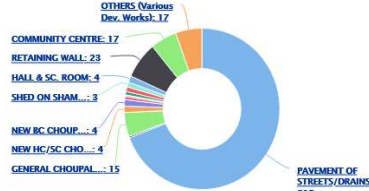

Development Works

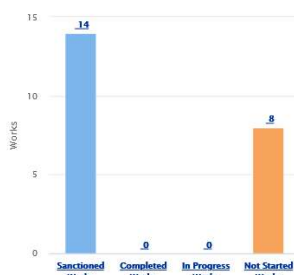

Work Status

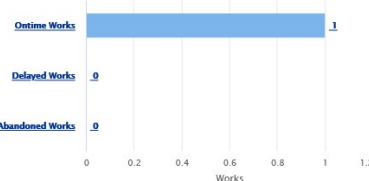

Installments (No. of works)

- 1st installment released: 6
- 1st installment UC submitted: 0
- 2nd installment released: 0
- 2nd installment UC submitted: 0

5 Best Performing Districts

Sr.No	Districts
1	AMBALA
2	JHAJJAR
3	NUH
4	PALWAL
5	

5 Least Performing Districts

Sr.No	Districts
1	AMBALA
2	JHAJJAR
3	NUH
4	PALWAL
5	

User Manual for Funds Disbursement Management System

2.3. Map View:

- Click on Map from left sidebar, then you will redirect to the map. Now you can select District, Block, Village and Correspondence sanction id from the dropdown then click on search button. A marker will be updated on the map and displaying a number of Works, Sanction id's of that particular area. User will also click on the marker.

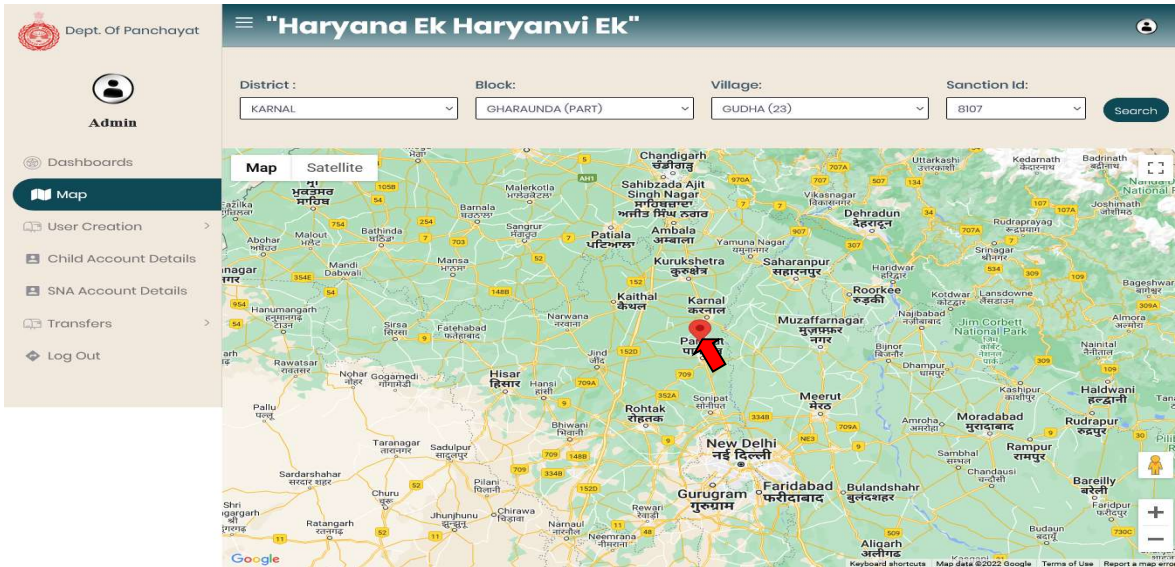

- A popup window will be appeared on the screen with the sanction id, number of works and view details. Click on view details option.

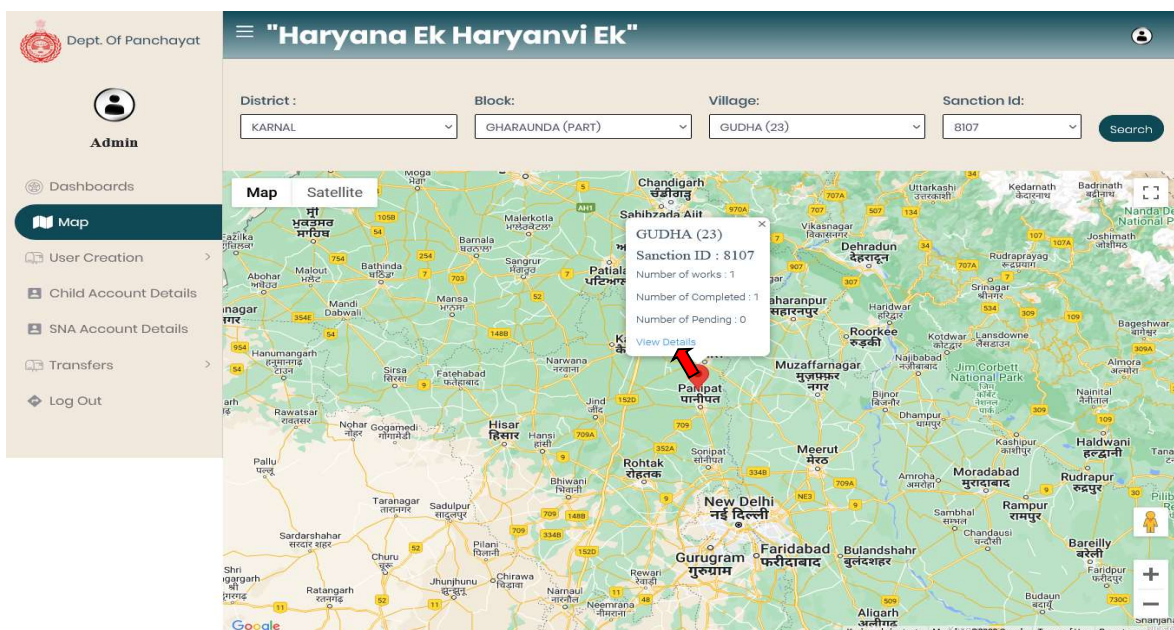

User Manual for Funds Disbursement Management System

- Now you can show the table with sanction id, sanction amount, Release Amount, Release Date, recommended by/CM Code, District, Constituency, Block, Village, Work Name, then Click on view image Image will be displayed for that particular sanction id.

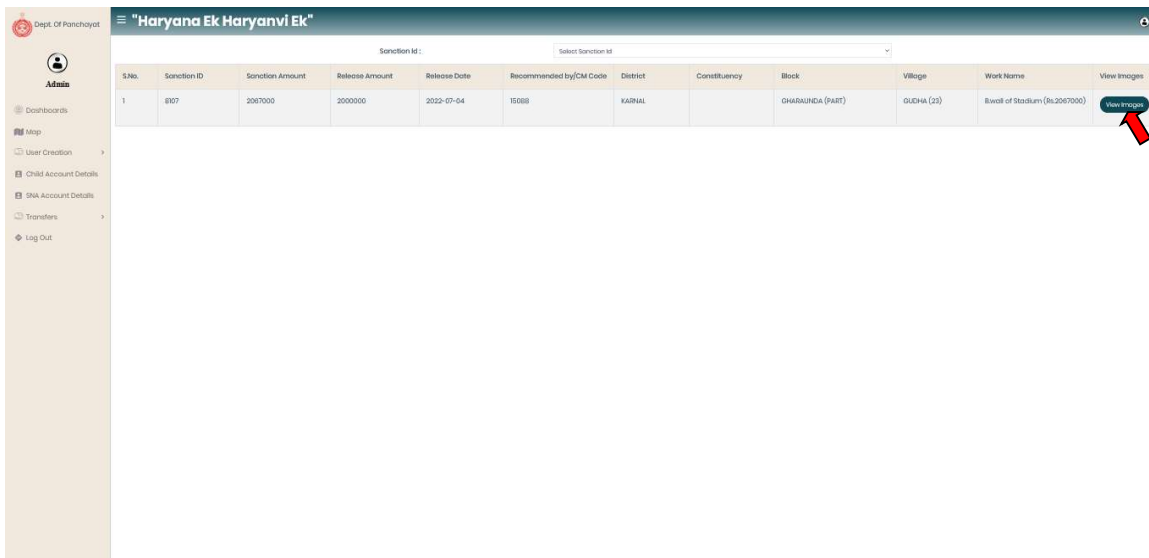

The screenshot shows a web application interface for the Dept. Of Panchayat. The main header is "Haryana Ek Haryanvi Ek". Below the header is a search bar for "Sanction ID:". A table displays the following data:

S.No.	Sanction ID	Sanction Amount	Release Amount	Release Date	Recommended by/CM Code	District	Constituency	Block	Village	Work Name	View Images
1	807	2087000	2000000	2022-07-04	15088	KARNAL		CHHARAUNDA (PART)	OLUHA (23)	Build of Stadium (Rs.2087000)	View Image

A red arrow points to the "View Image" button in the last column of the first row.

User Manual for Funds Disbursement Management System

2.4. User Creation:

- The Admin section login through which Admin can assign 4 Superadmin roles depending upon the districts through User creation -> Assign Assistant.
- Admin can create new user by User creation -> Create User by filling the form.

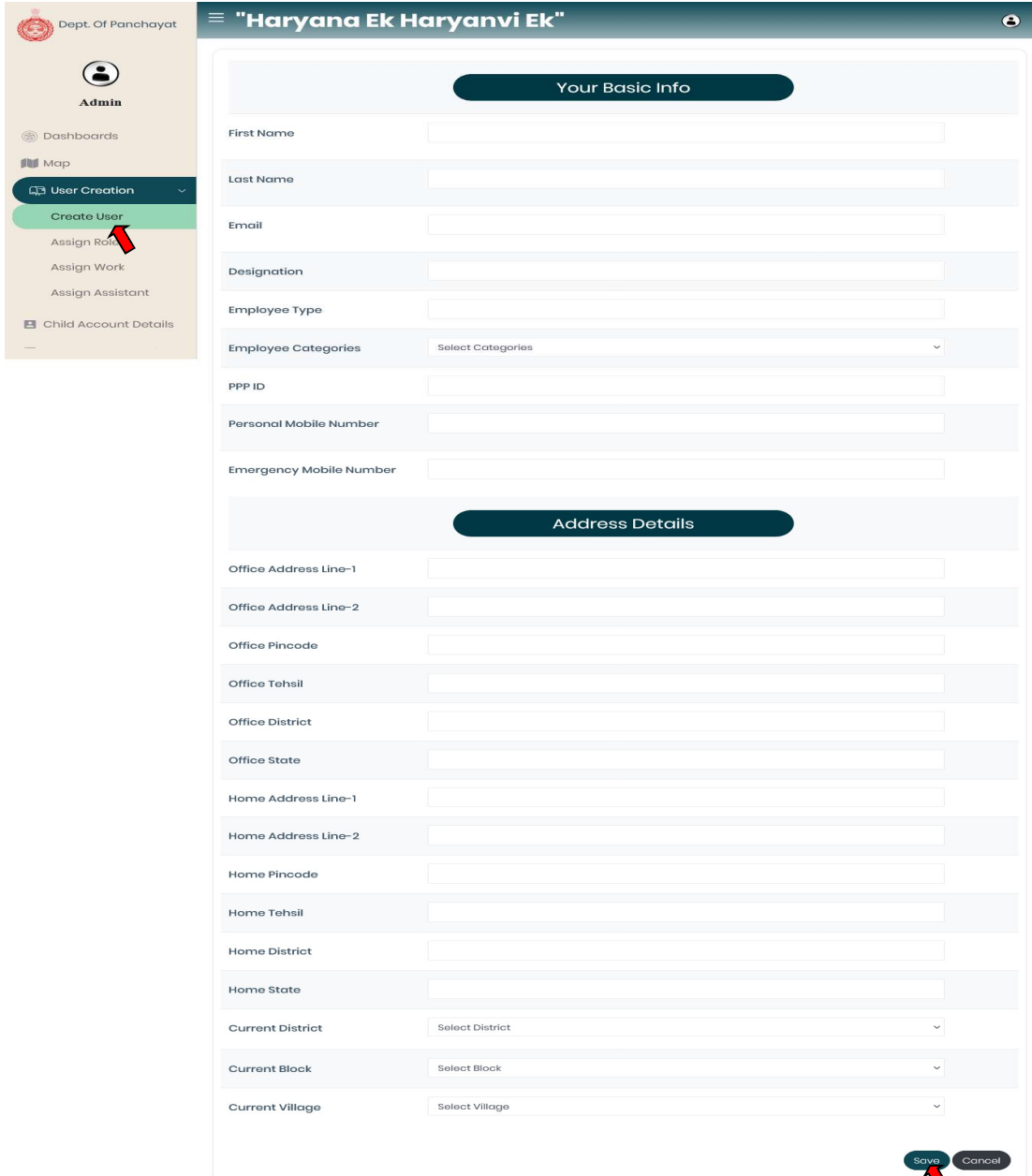

Dept. Of Panchayat

Admin

Dashboards

Map

User Creation

Create User

Assign Role

Assign Work

Assign Assistant

Child Account Details

"Haryana Ek Haryanvi Ek"

Your Basic Info

First Name

Last Name

Email

Designation

Employee Type

Employee Categories

PPP ID

Personal Mobile Number

Emergency Mobile Number

Address Details

Office Address Line-1

Office Address Line-2

Office Pincode

Office Tehsil

Office District

Office State

Home Address Line-1

Home Address Line-2

Home Pincode

Home Tehsil

Home District

Home State

Current District

Current Block

Current Village

Save

Cancel

User Manual for Funds Disbursement Management System

2.5. Assign Role:

- Admin can assign any role within the admin portal by User creation -> Assign Role. Admin can even assign Additional role through which user can assign additional role to a particular user and then that user can have multiple login authorities which are assigned to him.

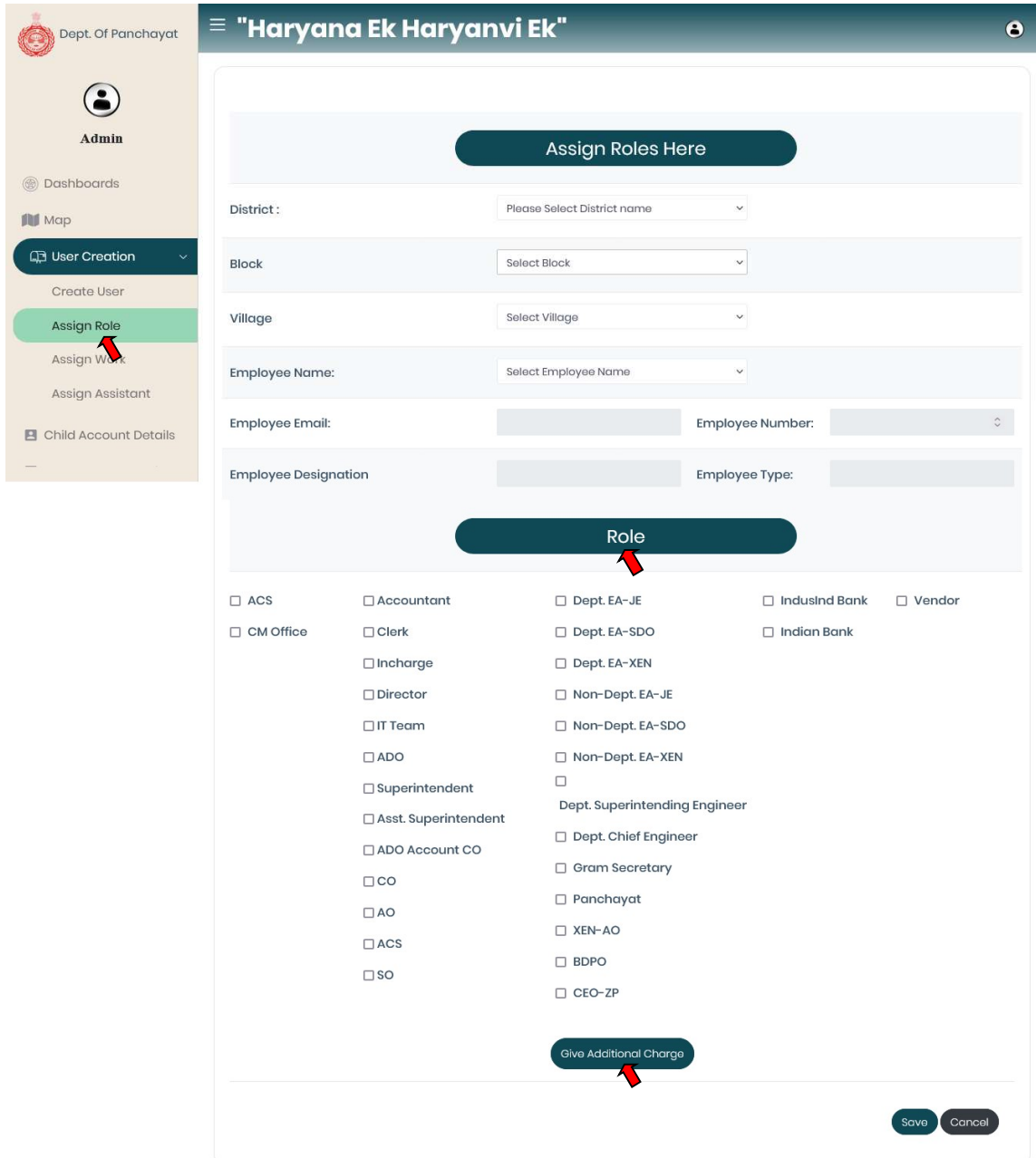

Dept. Of Panchayat

"Haryana Ek Haryanvi Ek"

Admin

Dashboards

Map

User Creation

Create User

Assign Role

Assign Work

Assign Assistant

Child Account Details

Assign Roles Here

District : Please Select District name

Block Select Block

Village Select Village

Employee Name: Select Employee Name

Employee Email: Employee Number:

Employee Designation Employee Type:

Role

<input type="checkbox"/> ACS	<input type="checkbox"/> Accountant	<input type="checkbox"/> Dept. EA-JE	<input type="checkbox"/> IndusInd Bank	<input type="checkbox"/> Vendor
<input type="checkbox"/> CM Office	<input type="checkbox"/> Clerk	<input type="checkbox"/> Dept. EA-SDO	<input type="checkbox"/> Indian Bank	
	<input type="checkbox"/> Incharge	<input type="checkbox"/> Dept. EA-XEN		
	<input type="checkbox"/> Director	<input type="checkbox"/> Non-Dept. EA-JE		
	<input type="checkbox"/> IT Team	<input type="checkbox"/> Non-Dept. EA-SDO		
	<input type="checkbox"/> ADO	<input type="checkbox"/> Non-Dept. EA-XEN		
	<input type="checkbox"/> Superintendent	<input type="checkbox"/>		
	<input type="checkbox"/> Asst. Superintendent	<input type="checkbox"/> Dept. Superintending Engineer		
	<input type="checkbox"/> ADO Account CO	<input type="checkbox"/> Dept. Chief Engineer		
	<input type="checkbox"/> CO	<input type="checkbox"/> Gram Secretary		
	<input type="checkbox"/> AO	<input type="checkbox"/> Panchayat		
<input type="checkbox"/> ACS		<input type="checkbox"/> XEN-AO		
<input type="checkbox"/> SO		<input type="checkbox"/> BDPO		
		<input type="checkbox"/> CEO-ZP		

Give Additional Charge

Save Cancel

User Manual for Funds Disbursement Management System

2.6. Assign Assistant:

- Admin can even assign assistant within the admin portal by User creation -> Assign Assistant by selecting District and choose Assistant by selecting Assistant name (A1 assistant, A2 assistant, A3 assistant, A4 assistant).

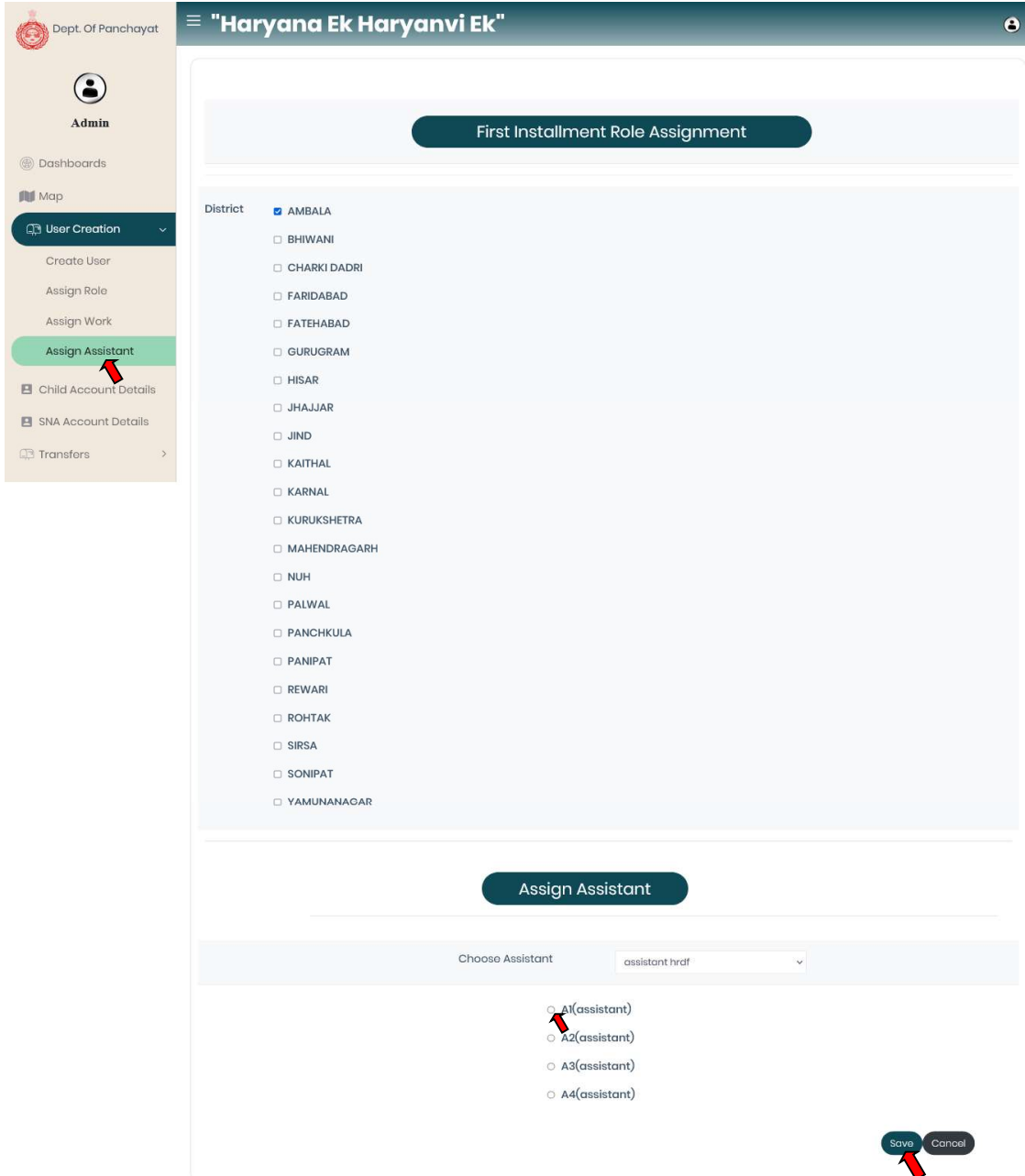

The screenshot displays the 'Assign Assistant' interface within the admin portal. The sidebar on the left shows the 'Assign Assistant' option highlighted in green. The main content area is titled 'First Installment Role Assignment' and features a list of districts under the 'District' heading. The 'AMBALA' district is selected with a checked checkbox. Below the district list, there is a section titled 'Assign Assistant' which includes a 'Choose Assistant' dropdown menu currently set to 'assistant hrdf'. Underneath, there are four radio button options: 'A1(assistant)', 'A2(assistant)', 'A3(assistant)', and 'A4(assistant)'. The 'A1(assistant)' option is selected. At the bottom right of the interface, there are 'Save' and 'Cancel' buttons, with the 'Save' button highlighted by a red arrow.

User Manual for Funds Disbursement Management System

2.7. Input Form:

- **Chief Executive Officer (CEO) Login:** CEO-ZP will fill the input form. Now Chief Executive Officer (CEO) (Zilla Parishad) can login using their credentials and then fill the Input Form of FDMS by filling the Letter no and Letter date in the top and then click on Input Form Table button. Now fill the input form table with mandatory supporting documents like: Upload Resolution, Upload Estimate, Upload Brief History, Upload Site Plan, Upload Forwarding Letter and click on save button.

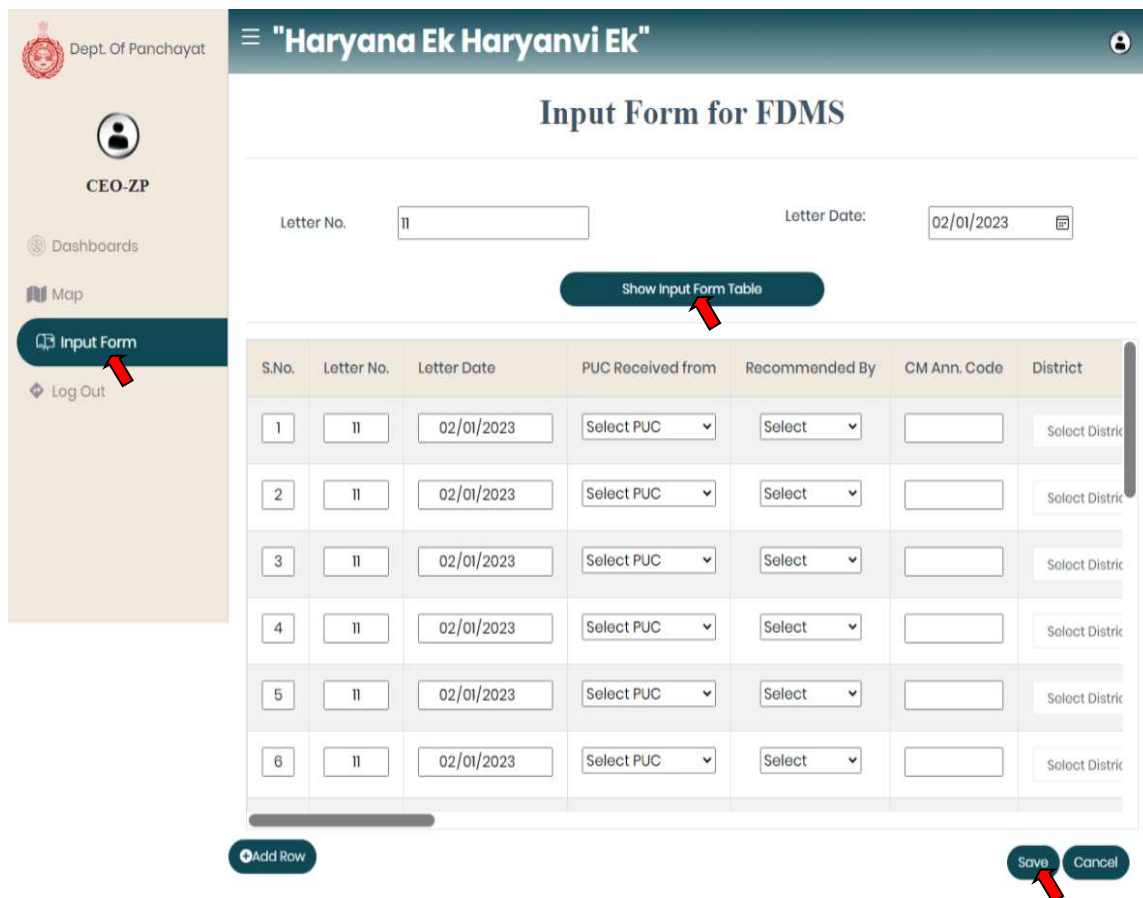

Dept. Of Panchayat

"Haryana Ek Haryanvi Ek"

CEO-ZP

Dashboards

Map

Input Form

Log Out

Letter No. 11

Letter Date: 02/01/2023

Show Input Form Table

S.No.	Letter No.	Letter Date	PUC Received from	Recommended By	CM Ann. Code	District
1	11	02/01/2023	Select PUC	Select		Select District
2	11	02/01/2023	Select PUC	Select		Select District
3	11	02/01/2023	Select PUC	Select		Select District
4	11	02/01/2023	Select PUC	Select		Select District
5	11	02/01/2023	Select PUC	Select		Select District
6	11	02/01/2023	Select PUC	Select		Select District

Add Row

Save Cancel

User Manual for Funds Disbursement Management System

2.8. Assistant Login:

- **Dashboard View:**

Assistant Dashboard will open, assistant can check the status of works with Total Received Work, Total Works Sanctioned, Total Works Pending, Total New Works status of work.

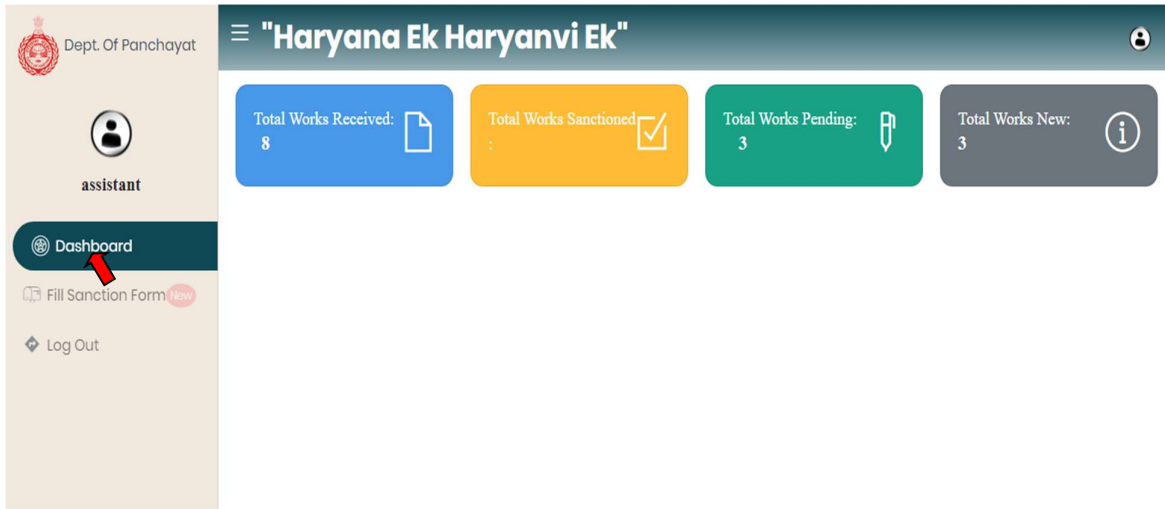

User Manual for Funds Disbursement Management System

- **Sanction Form:**

- Once input form is filled by CEO-ZP then assistant of district allotted them will login with their given credentials, need to fill the sanction form which is split up within two sections i.e. sanction form and annexure.
- When new work assigns the alert will show on assistant dashboard- New New will be blink on the assistant dashboard for new record.

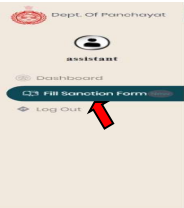

Dept. Of Panchayat
assistant
Dashboard
Fill Sanction Form
Log Out

"Haryana Ek Haryanvi Ek"

From: Managing Director, Haryana Rural Development Fund Administration Board, Plot No. 3, Sector 29 A, Medhwa Marg, Chandigarh

To: The Chief Executive Officer, Zila Parishad, [Select District]

Memo No. HRDF-2022/[] Dated: 15-02-23

Subject: Implementation of schemes/project under section 6(5) of Haryana Rural Development Act, 1986.

- Reference your letter No. [select date] no. [PUC NO] dated [select date] on the subject cited above.
- The development schemes as shown in attached Annexure 'A' to your district have been examined and accorded administrative approval.
- The funds for the execution of the sanctioned schemes are being released by transferring the funds through the Real Time Gross Settlement (RTGS) System directly in the bank account of concerned Executive Engineer (Panchayati Raj) / Gram Panchayats as per Annexure-A.

Sr.No.	No. of works	Fig. in Rupees	Sanctioned	Released
1	[]	[]	[]	[]

4. The above sanction is subject to the following conditions:-

- That ground clearing etc. affecting the provisions made in the approved estimate with proposed work to be executed at the site of the estimates be got done by the executing Agency. It should also be ensured that if any money has been earmarked from some other fund for the same work(s) at district level, this amount must be returned to this office.
- It should be ensured that the funds have not been sanctioned earlier for the same works/ purpose. In case of works relating to streets, it must be verified that the proposed Roster/Streets are unconstructed or not use-worthy.**
- That no area is served which is unauthorized. The colonies where the works to be executed is duly authorized by the Town and Country Planning Department in case they fall under notified area.
- That the drainage arrangements will be finalized and it will be ensured that the waste water is disposed of quickly. The certificate will be given by the XEN/SDO concerned.
- That the provisions given in the technical note attached in the estimate will be strictly followed.
- That the proposed work/scheme is not included in any other scheme. A certificate to this effect should be recorded by the XEN/SDO.
- That the pre-measures have been taken and provisions made in the estimates are correct.
- Detailed estimates with drawings on per site conditions be prepared and got approved from the competent authority before actual execution.
- The amount released should be utilized within a period of six months from the date of release of funds.
- Standard designs for the construction of MC/BC Choupals and additional school rooms have been prepared by CEDRO Haryana and copies of the same can be obtained from XEN/SDO for executing the work.
- The proposed work/scheme are being sanctioned/released subject to the condition that these works/projects are covered under the guidelines/instructions issued by the State Govt. from time to time. The Gram Panchayat be advised to execute the work strictly in accordance with the guidelines. It shall also be ensured that funds have not been sanctioned earlier for the same work.
- The detailed guidelines and policy decisions issued by additional chief secretary to government of Haryana development and panchayats Department vide letters No. 8348-133 dated 7.6.2017 and any other instructions issued by the Government from time to time for the execution of development work shall strictly be followed. The funds shall be transferred within a day in the bank account of concerned gram panchayat as per the said policies.
- The physical and financial status of each work sanctioned under HRDF be updated regularly in work monitoring system available on web application at <http://192.168.27.103/rtgs/> refer to Memo No.1/2019/32228-71 dated 3.7.2019. The user credentials of executive Engineers (HR) Panchayati Samitis & Gram Panchayats have already been created & shared through email by the IT Cell of Development & Panchayats Department.
- The second installment(s), if any, shall be released only after receipt of UC(s) of earlier installment(s) accompanied with the report of BDO & SDO/CEO / CDDP & CE/ERO as directed vide letter No.32012-54 dated 19.12.2014 issued by HRDF Board.**
- The Accounts of these projects/scheme should be subject to audit by the director local fund accounts & HRDF Board officers and officials.
- In any circumstances, the interest accrued on the released amount not to be treated as part of sanctioned amount and the same must be returned to HRDF Board.
- Duplicate copy of estimates of each scheme is also sent herewith for records. The receipt of this letter may please be acknowledged.
- Duplicate copy of estimates of each scheme is also sent herewith for records. The receipt of this letter may please be acknowledged.

Administrative Officer
Haryana Rural Development Funds
Administration Board
Chandigarh

Enclst No. HRDF-2022/[] Dated: 15-02-23

• A copy of above is forwarded to the following for information and necessary action please:

- The Deputy Commissioner, [Select District]
- The Chief Executive Officer, Zila Parishad, [Select District]
- The District Development & Panchayat Officer, [Select District]
- The BDO/SDO, As per Annexure 'A'
- The Sarpanch, As per Annexure 'A'
- The Accounts Officer, HRDF Board, Chandigarh. He is requested to transfer the funds (as per detail in Annexure 'A') to the concerned executing agency.
- The Assistant Programmer, HRDF Board, Chandigarh.

Administrative Officer
Haryana Rural Development Funds
Administration Board
Chandigarh

Enclst No. HRDF-2022/[] Dated: 15-02-23

- A copy is forwarded to Director Local Audit, Haryana, Chandigarh.
- A copy is forwarded to Chief Engineer, Panchayati Raj, Haryana, Chandigarh. He is directed to ensure execution of work in time, maintenance of quality by inspecting the sites from time to time.

CC: The PS to DPM for the information of Hon'ble Development & Panchayats Minister, Government of Haryana, Chandigarh.

Annexure "A" List of Schemes/Works approved under HRDF during 2022-23

District: [Select District] Letter No. [] Dated: [dd-mm-yyyy]

Debit Note No. [] Dated: [dd-mm-yyyy]

Sr.No	Block	Village	Name Of Work	Amount Sanctioned
[]	[Select Block]	[Select Village]	[Select work]	[]
[]	[Select Block]	[Select Village]	[Select work]	[]
[]	[Select Block]	[Select Village]	[Select work]	[]
[]	[Select Block]	[Select Village]	[Select work]	[]
[]	[Select Block]	[Select Village]	[Select work]	[]
[]	[Select Block]	[Select Village]	[Select work]	[]

Submit

Page 15 of 37

User Manual for Funds Disbursement Management System

2.9. Instalment approval workflow with flow charts:

The approval of sanction will be done by authorities according to sanction amount

- MD amount less than 1Cr
- ACS amount between 1Cr-2.5Cr
- DPM amount between 2.5Cr-10Cr
- CM amount greater than 10Cr

For a particular letter no and letter date combination, if the sanction form is filled, then the approval workflow of instalment starts.

The approval work flow of instalment goes from:

Superintendent --> ADO --> MD/ACS/DPM/CM --> MD-->ADO (for signature and Final publish) --> SO (publish advice note) --> AO (AO signature) -->MD (MD signature) --> AO (upload dispatch file column) --> AO (send email to HARCO) --> final payment to bank (send file to bank button)

- **MD amount less than 1Cr**

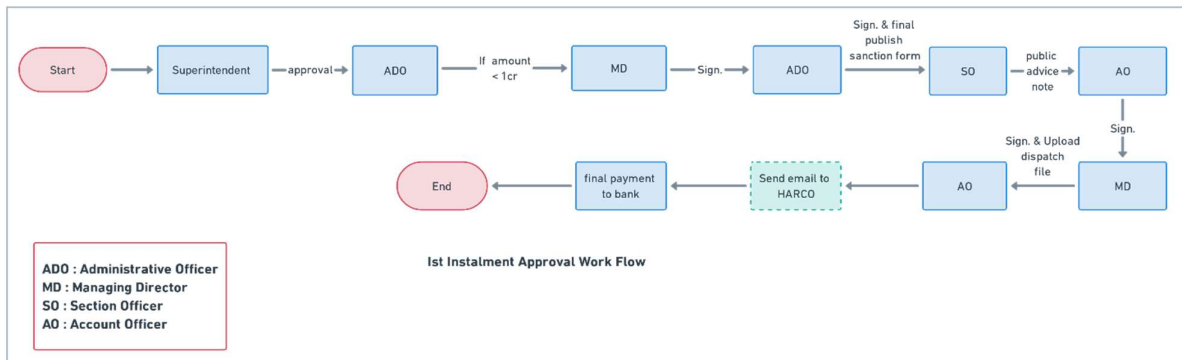

User Manual for Funds Disbursement Management System

MD/Director login:

- Dashboard View:**

MD Dashboard will open, you can check the status of work by selecting scheme, District, Block and Village from dropdown. Bar charts and Pie charts also show the status of work. Also check the 5 Best and least Performing Districts in the dashboard.

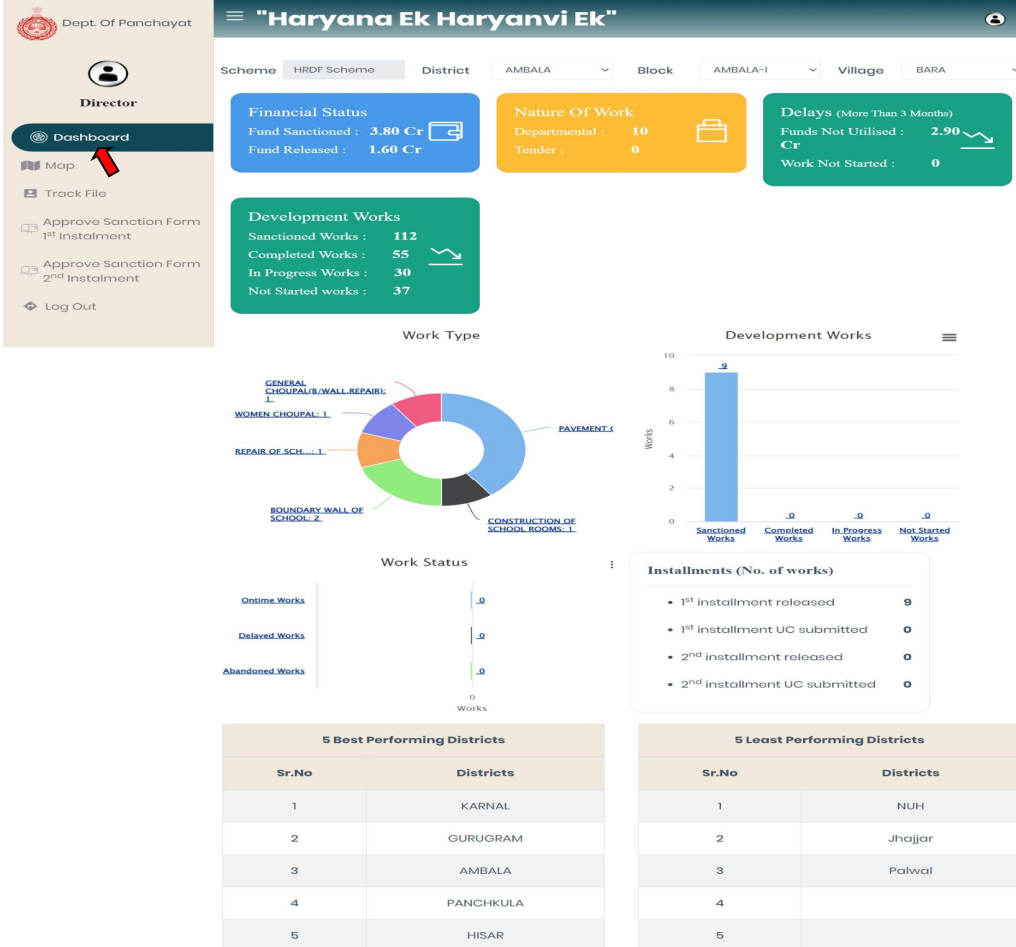

The dashboard displays the following information:

- Financial Status:** Fund Sanctioned : 3.80 Cr, Fund Released : 1.60 Cr
- Nature Of Work:** Departmental : 10, Tender : 0
- Delays (More Than 3 Months):** Funds Not Utilised : 2.90 Cr, Work Not Started : 0
- Development Works:** Sanctioned Works : 112, Completed Works : 55, In Progress Works : 30, Not Started works : 37

Work Type (Donut Chart):

- PAVEMENT
- CONSTRUCTION OF SCHOOL ROOMS-1
- BOUNDARY WALL OF SCHOOL-2
- REPAIR OF SCH...-1
- WOMEN CHOUPAL-1
- GENERAL CHOUPAL (WALL REPAIR)

Development Works (Bar Chart):

Category	Works
Sanctioned Works	9
Completed Works	0
In Progress Works	0
Not Started Works	0

Work Status:

- On time Works: 0
- Delayed Works: 0
- Abandoned Works: 0

Installments (No. of works):

- 1st installment released: 9
- 1st installment UC submitted: 0
- 2nd installment released: 0
- 2nd installment UC submitted: 0

5 Best Performing Districts:

Sr.No	Districts
1	KARNAL
2	GURUGRAM
3	AMBALA
4	PANCHKULA
5	HISAR

5 Least Performing Districts:

Sr.No	Districts
1	NUH
2	Jhajjar
3	Palwal
4	
5	

User Manual for Funds Disbursement Management System

- Track File:**
 Click on Track file from the left side nav of MD login, MD can track the file for particular district, block and village by selecting the CFMS no. and CFMS date of that file for instalment work.

Track File for instalment:

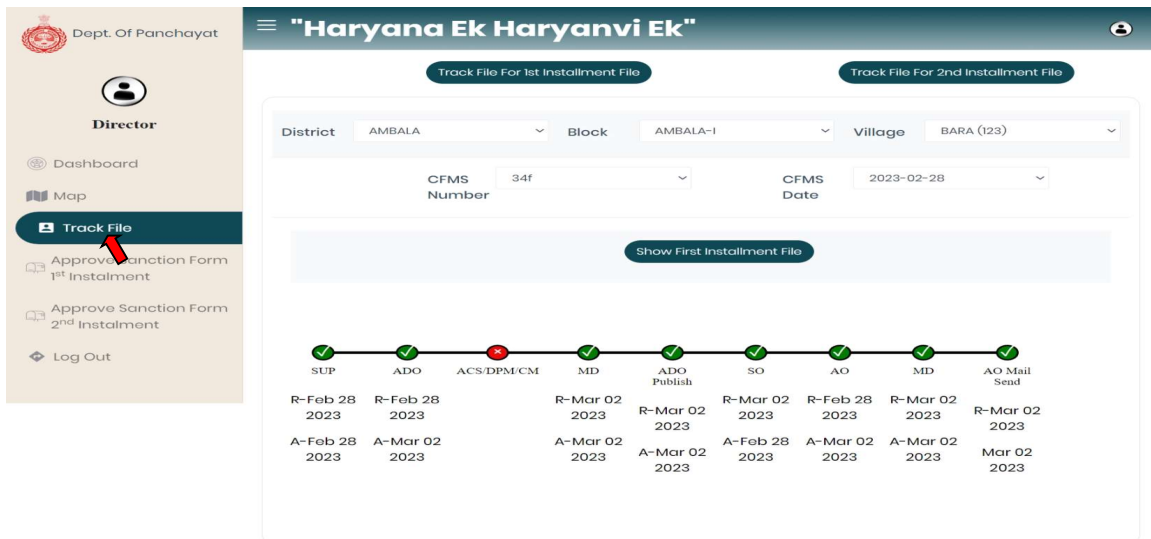

- Approve Sanction Form Instalment:**
 Click on Approve Sanction Form Instalment from the left side nav bar of MD login, Now MD will approve the instalment sanction by signing the sanction form digitally.

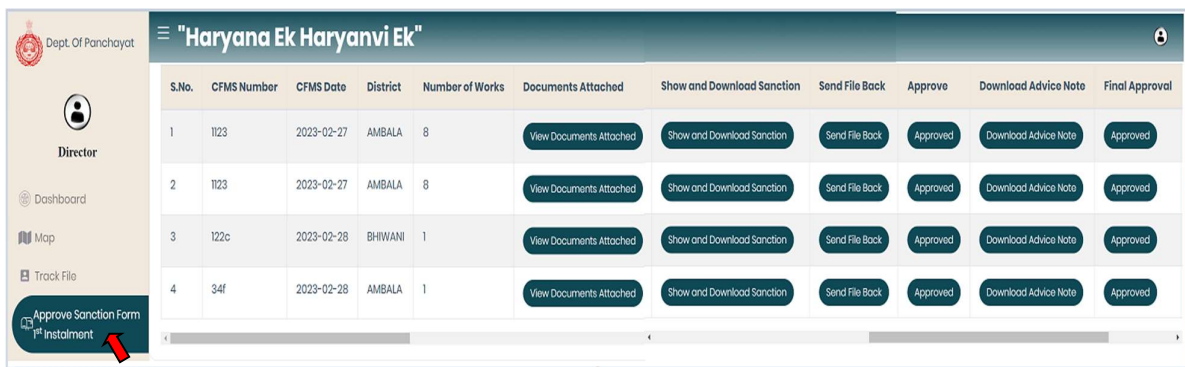

S.No.	CFMS Number	CFMS Date	District	Number of Works	Documents Attached	Show and Download Sanction	Send File Back	Approve	Download Advice Note	Final Approval
1	1123	2023-02-27	AMBALA	8	View Documents Attached	Show and Download Sanction	Send File Back	Approved	Download Advice Note	Approved
2	1123	2023-02-27	AMBALA	8	View Documents Attached	Show and Download Sanction	Send File Back	Approved	Download Advice Note	Approved
3	122c	2023-02-28	BHIWANI	1	View Documents Attached	Show and Download Sanction	Send File Back	Approved	Download Advice Note	Approved
4	34f	2023-02-28	AMBALA	1	View Documents Attached	Show and Download Sanction	Send File Back	Approved	Download Advice Note	Approved

MD logout.

User Manual for Funds Disbursement Management System

- ACS amount between 1Cr-2.5Cr

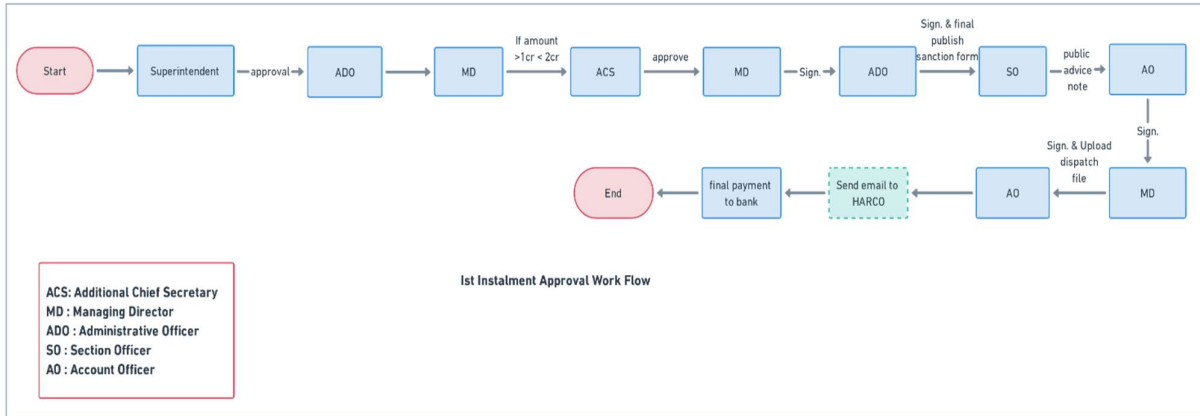

User Manual for Funds Disbursement Management System

ACS login:

- Dashboard View:**

ACS Dashboard will open, you can check the status of work by selecting scheme, District, Block and Village from dropdown. Bar charts and Pie charts also show the status of work. Also check the 5 Best and least Performing Districts in the dashboard.

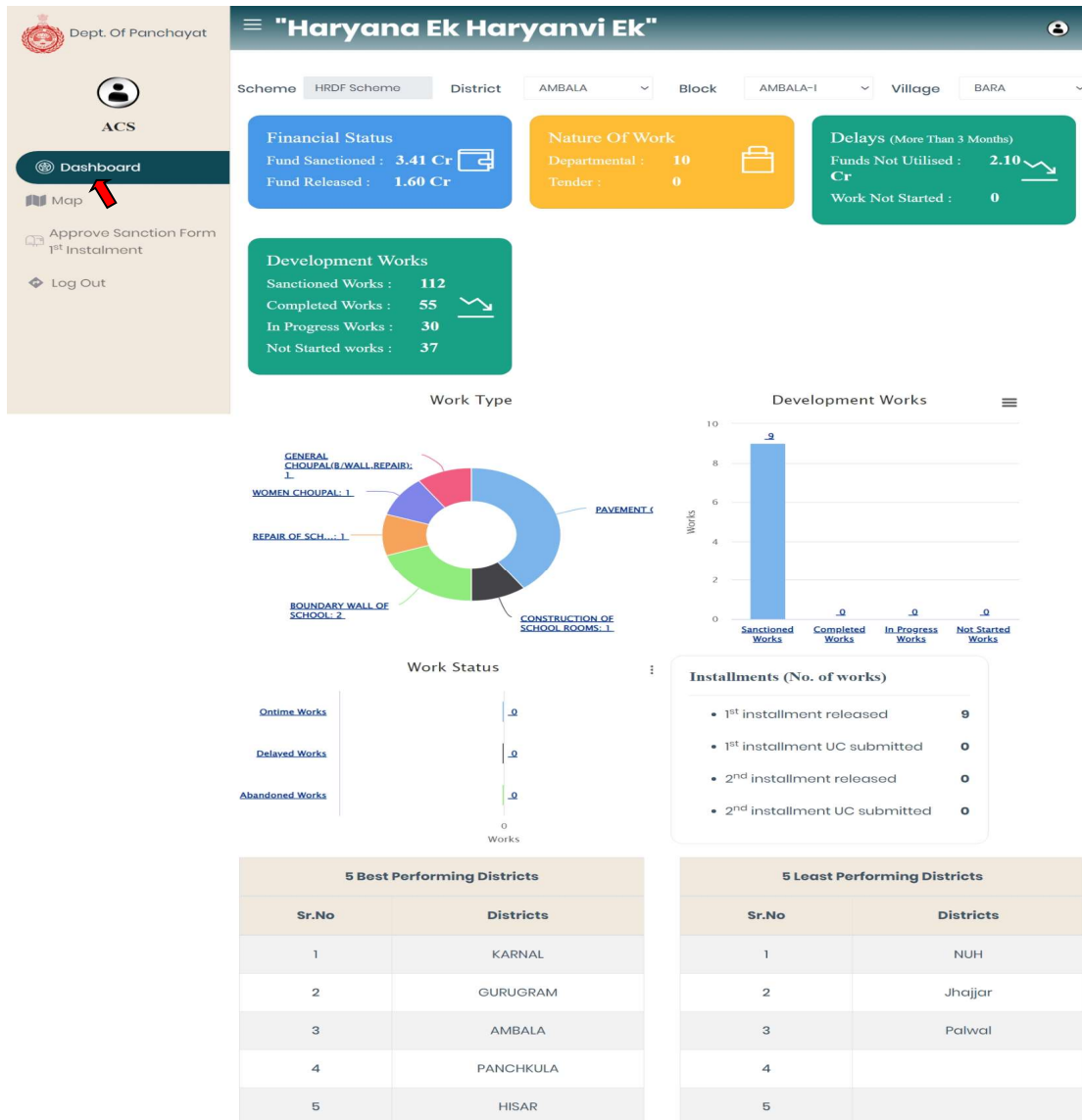

Dept. Of Panchayat

ACS

Dashboard

Map

Approve Sanction Form 1st Instalment

Log Out

"Haryana Ek Haryanvi Ek"

Scheme: HRDF Scheme | District: AMBALA | Block: AMBALA-1 | Village: BARA

Financial Status
Fund Sanctioned : 3.41 Cr
Fund Released : 1.60 Cr

Nature Of Work
Departmental : 10
Tender : 0

Delays (More Than 3 Months)
Funds Not Utilised : 2.10 Cr
Work Not Started : 0

Development Works
Sanctioned Works : 112
Completed Works : 55
In Progress Works : 30
Not Started works : 37

Work Type

Development Works

Work Status

Installments (No. of works)

- 1st installment released: 9
- 1st installment UC submitted: 0
- 2nd installment released: 0
- 2nd installment UC submitted: 0

5 Best Performing Districts

Sr.No	Districts
1	KARNAL
2	GURUGRAM
3	AMBALA
4	PANCHKULA
5	HISAR

5 Least Performing Districts

Sr.No	Districts
1	NUH
2	Jhajjar
3	Palwal
4	
5	

User Manual for Funds Disbursement Management System

- Track File:**
 Click on Track file from the left side nav of ACS login, ACS can track the file for particular district, block and village by selecting the CFMS no. and CFMS date of that file for instalment work.

Track File for instalment:

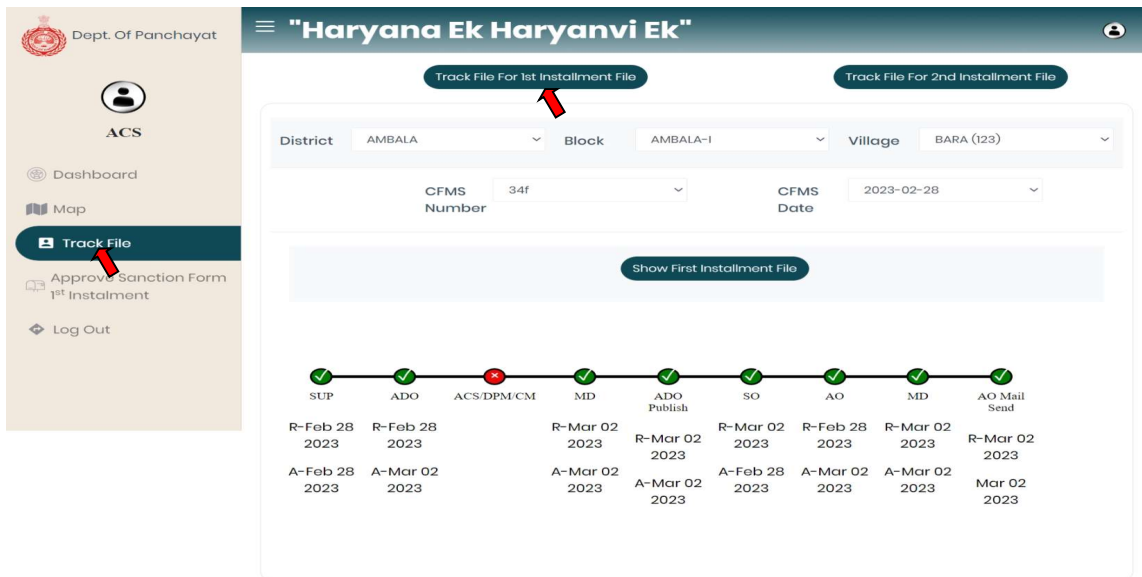

- Approve Sanction Form Instalment:**
 Click on Approve Sanction Form 1st Instalment from the left side nav bar of ACS login, Now ACS will approve the 1st instalment sanction by click approve button.

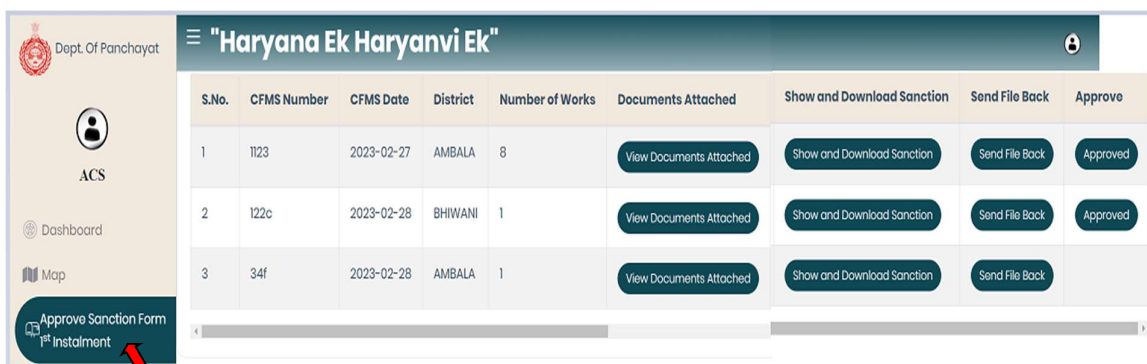

S.No.	CFMS Number	CFMS Date	District	Number of Works	Documents Attached	Show and Download Sanction	Send File Back	Approve
1	1123	2023-02-27	AMBALA	8	View Documents Attached	Show and Download Sanction	Send File Back	Approved
2	122c	2023-02-28	BHIWANI	1	View Documents Attached	Show and Download Sanction	Send File Back	Approved
3	34f	2023-02-28	AMBALA	1	View Documents Attached	Show and Download Sanction	Send File Back	

ACS logout.

User Manual for Funds Disbursement Management System

- DPM- amount between 2.5Cr-10Cr

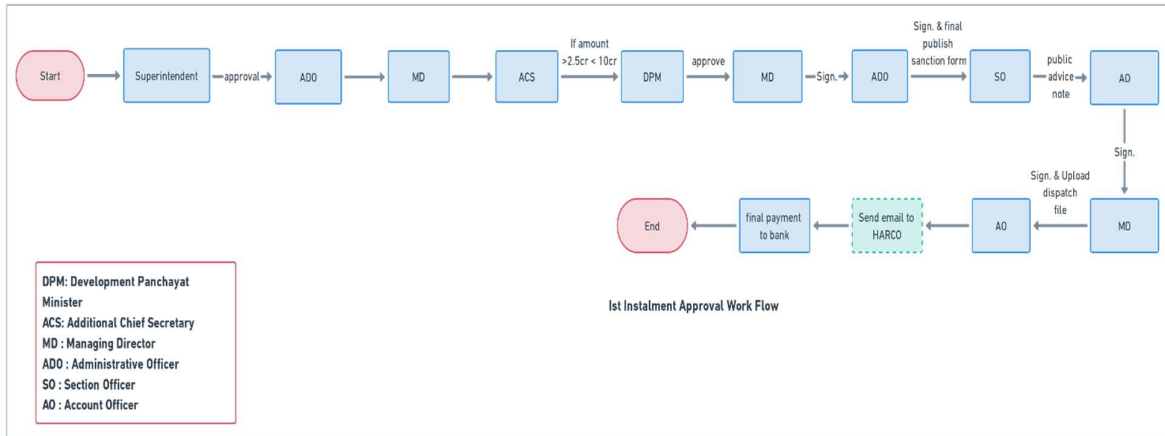

User Manual for Funds Disbursement Management System

DPM login:

- **Dashboard View:**

DPM Dashboard will open, you can check the status of work by selecting scheme, District, Block and Village from dropdown. Bar charts and Pie charts also show the status of work. Also check the 5 Best and least Performing Districts in the dashboard.

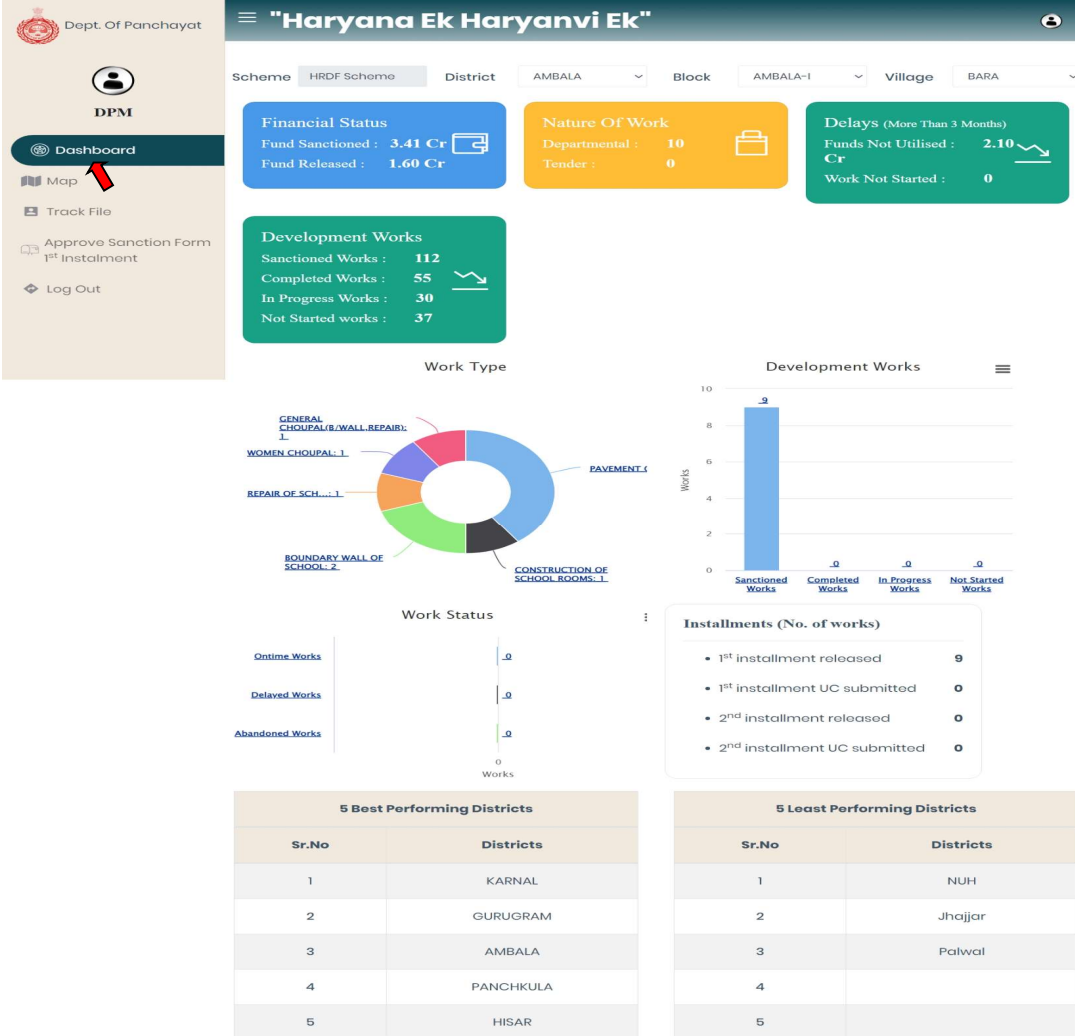

Dept. Of Panchayat

"Haryana Ek Haryanvi Ek"

Scheme: HRDF Scheme | District: AMBALA | Block: AMBALA-I | Village: BARA

Financial Status

Fund Sanctioned : 3.41 Cr

Fund Released : 1.60 Cr

Nature Of Work

Departmental : 10

Tender : 0

Delays (More Than 3 Months)

Funds Not Utilised : 2.10 Cr

Work Not Started : 0

Development Works

Sanctioned Works : 112

Completed Works : 55

In Progress Works : 30

Not Started works : 37

Work Type

GENERAL CHOUPAL(B,WALL,REPAIR): 1

WOMEN CHOUPAL: 1

REPAIR OF SCH...: 1

BOUNDARY WALL OF SCHOOL: 2

CONSTRUCTION OF SCHOOL ROOMS: 1

PAVEMENT: 1

Development Works

Sanctioned Works: 9

Completed Works: 0

In Progress Works: 0

Not Started Works: 0

Work Status

On time Works: 0

Delayed Works: 0

Abandoned Works: 0

Installments (No. of works)

- 1st installment released: 9
- 1st installment UC submitted: 0
- 2nd installment released: 0
- 2nd installment UC submitted: 0

5 Best Performing Districts	
Sr.No	Districts
1	KARNAL
2	GURUGRAM
3	AMBALA
4	PANCHKULA
5	HISAR

5 Least Performing Districts	
Sr.No	Districts
1	NUH
2	Jhajjar
3	Palwal
4	
5	

User Manual for Funds Disbursement Management System

- Track File:**
 Click on Track file from the left side nav of DPM login, DPM can track the file for particular district, block and village by selecting the CFMS no. and CFMS date of that file for instalment work.

Track File for instalment:

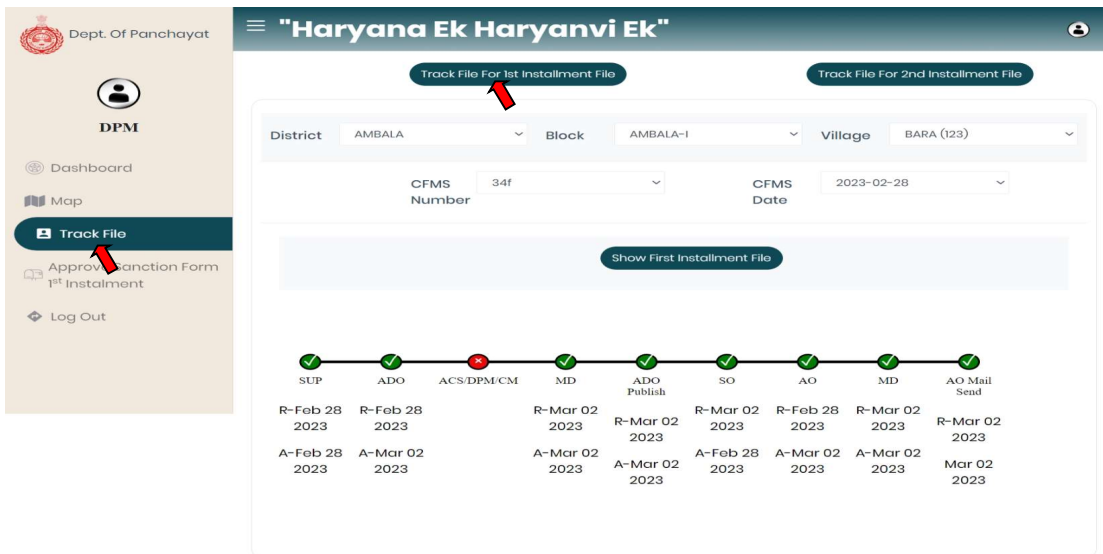

- Approve Sanction Form Instalment:**
 Click on Approve Sanction Form 1st Instalment from the left side nav bar of DPM login, Now DPM will approve the instalment sanction by click approve button.

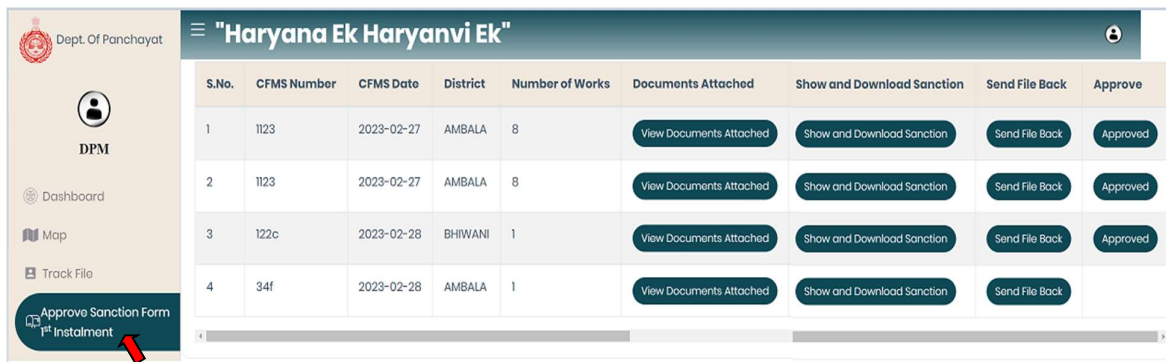

S.No.	CFMS Number	CFMS Date	District	Number of Works	Documents Attached	Show and Download Sanction	Send File Back	Approve
1	1123	2023-02-27	AMBALA	8	View Documents Attached	Show and Download Sanction	Send File Back	Approved
2	1123	2023-02-27	AMBALA	8	View Documents Attached	Show and Download Sanction	Send File Back	Approved
3	122c	2023-02-28	BHIWANI	1	View Documents Attached	Show and Download Sanction	Send File Back	Approved
4	34f	2023-02-28	AMBALA	1	View Documents Attached	Show and Download Sanction	Send File Back	

DPM logout.

User Manual for Funds Disbursement Management System

- Cm amount greater than 10Cr

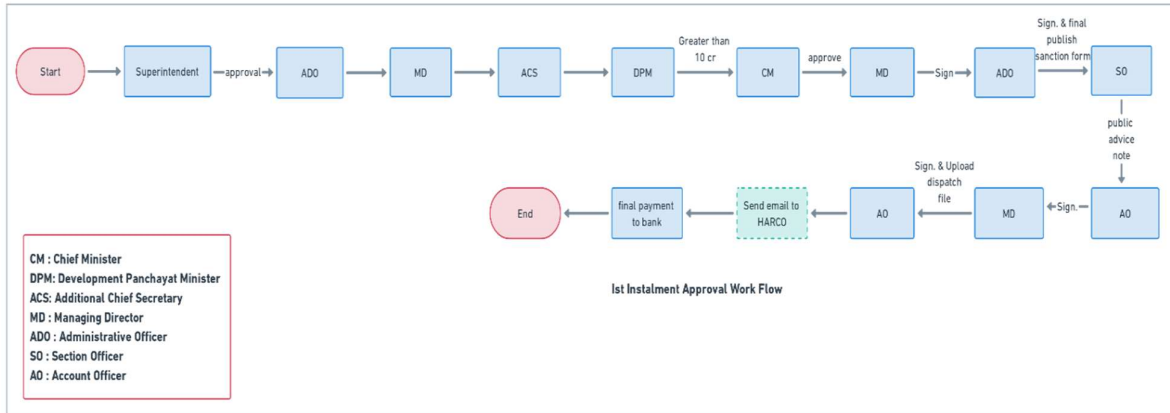

User Manual for Funds Disbursement Management System

CM office login:

- **Dashboard View:**

CM Dashboard will open, you can check the status of work by selecting scheme, District, Block and Village from dropdown. Bar charts and Pie charts also show the status of work. Also check the 5 Best and least Performing Districts in the dashboard.

Dept. Of Panchayat

CM Haryana

Dashboard

Map

Track File

Approve Sanction Form 1st Instalment

Log Out

"Haryana Ek Haryanvi Ek"

Scheme: HRDF Scheme | District: AMBALA | Block: AMBALA-I | Village: BARA

Financial Status

Fund Sanctioned : 3.41 Cr

Fund Released : 1.60 Cr

Nature Of Work

Departmental : 10

Tender : 0

Delays (More Than 3 Months)

Funds Not Utilised : 2.10 Cr

Work Not Started : 0

Development Works

Sanctioned Works : 112

Completed Works : 55

In Progress Works : 30

Not Started works : 37

Work Type

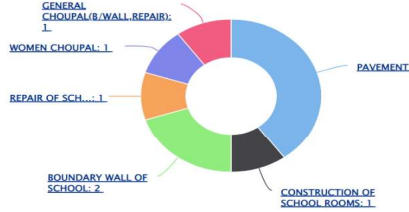

Development Works



Work Status

Ontime Works : 0

Delayed Works : 0

Abandoned Works : 0

Installments (No. of works)

- 1st installment released : 9
- 1st installment UC submitted : 0
- 2nd installment released : 0
- 2nd installment UC submitted : 0

5 Best Performing Districts	
Sr.No	Districts
1	KARNAL
2	GURUGRAM
3	AMBALA
4	PANCHKULA
5	HISAR

5 Least Performing Districts	
Sr.No	Districts
1	NUH
2	Jhajjar
3	Palwal
4	
5	

User Manual for Funds Disbursement Management System

- Track File:**
 Click on Track file from the left side nav of CM login, CM can track the file for particular district, block and village by selecting the CFMS no. and CFMS date of that file for instalment work.

Track File for instalment:

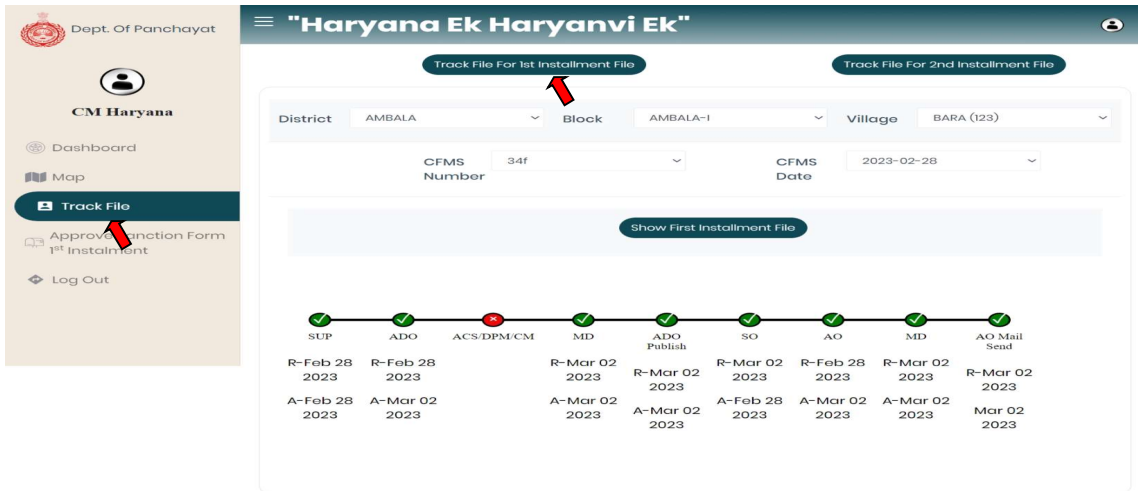

- Approve Sanction Form 1st Instalment:**
 Click on Approve Sanction Form 1st Instalment from the left side nav bar of CM login, Now CM will approve the 1st instalment sanction by click approve button.

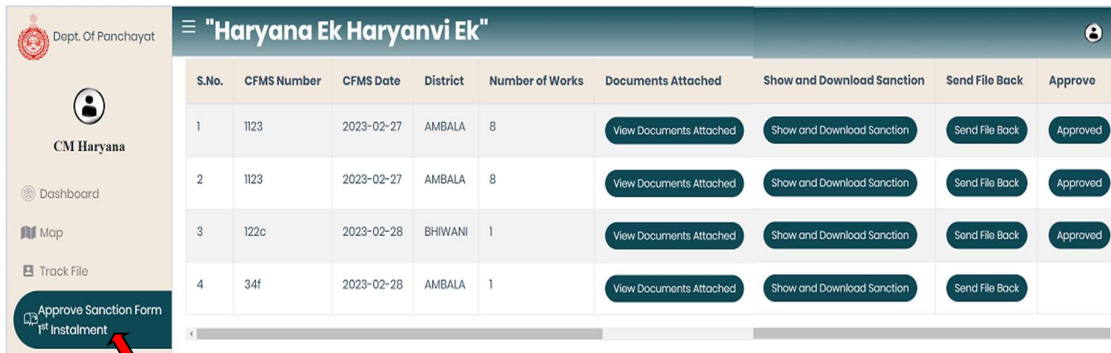

S.No.	CFMS Number	CFMS Date	District	Number of Works	Documents Attached	Show and Download Sanction	Send File Back	Approve
1	1123	2023-02-27	AMBALA	8	View Documents Attached	Show and Download Sanction	Send File Back	Approved
2	1123	2023-02-27	AMBALA	8	View Documents Attached	Show and Download Sanction	Send File Back	Approved
3	1226	2023-02-28	BHIWANI	1	View Documents Attached	Show and Download Sanction	Send File Back	Approved
4	34f	2023-02-28	AMBALA	1	View Documents Attached	Show and Download Sanction	Send File Back	Approve

CM Office logout.

User Manual for Funds Disbursement Management System

3. Executive Agency Login:

- Inspection module starts with executive agency login/ XEN login.

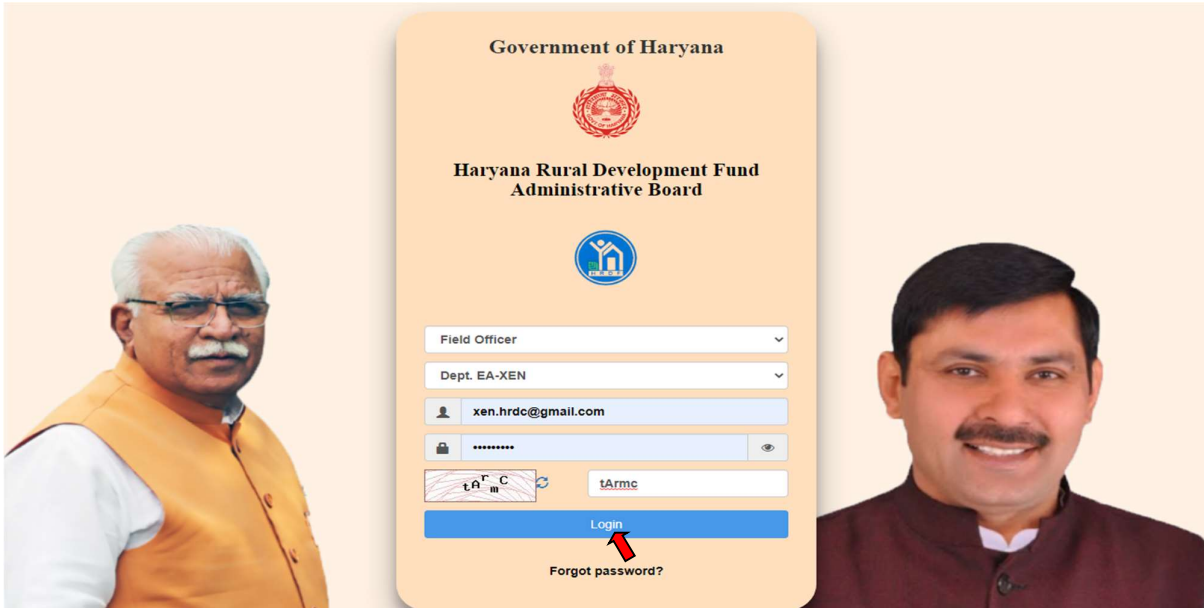

3.1. Sanction Works:

- Click on Sanction Works from the side nav of XEN login, then XEN will be able to check new sanction works.

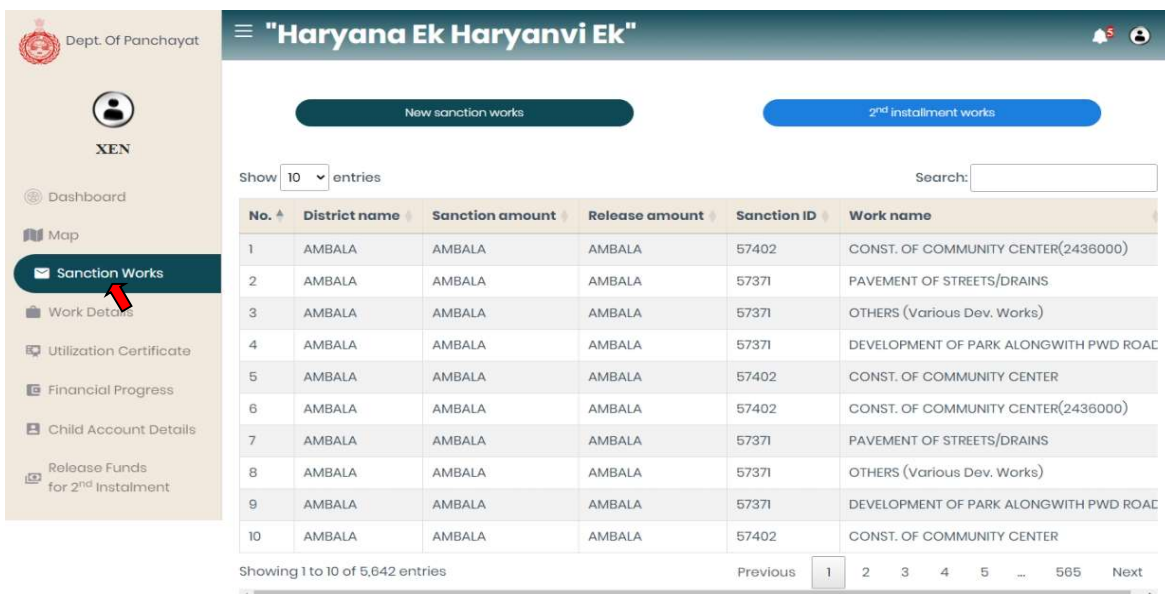

No.	District name	Sanction amount	Release amount	Sanction ID	Work name
1	AMBALA	AMBALA	AMBALA	57402	CONST. OF COMMUNITY CENTER(2438000)
2	AMBALA	AMBALA	AMBALA	57371	PAVEMENT OF STREETS/DRAINS
3	AMBALA	AMBALA	AMBALA	57371	OTHERS (Various Dev. Works)
4	AMBALA	AMBALA	AMBALA	57371	DEVELOPMENT OF PARK ALONGWITH PWD ROAC
5	AMBALA	AMBALA	AMBALA	57402	CONST. OF COMMUNITY CENTER
6	AMBALA	AMBALA	AMBALA	57402	CONST. OF COMMUNITY CENTER(2438000)
7	AMBALA	AMBALA	AMBALA	57371	PAVEMENT OF STREETS/DRAINS
8	AMBALA	AMBALA	AMBALA	57371	OTHERS (Various Dev. Works)
9	AMBALA	AMBALA	AMBALA	57371	DEVELOPMENT OF PARK ALONGWITH PWD ROAC
10	AMBALA	AMBALA	AMBALA	57402	CONST. OF COMMUNITY CENTER

User Manual for Funds Disbursement Management System

3.2. Work Details Form:

- Click on Work Detail Form from side nav. XEN will select district, block, village, sanction id and work id from the dropdown, then XEN will allot a particular work to JE and SDO. He will fill the details for work detail form and tender details automatically fetch from HEW portal, then XEN will submit the form with all the details.
XEN login--> Work Detail Form

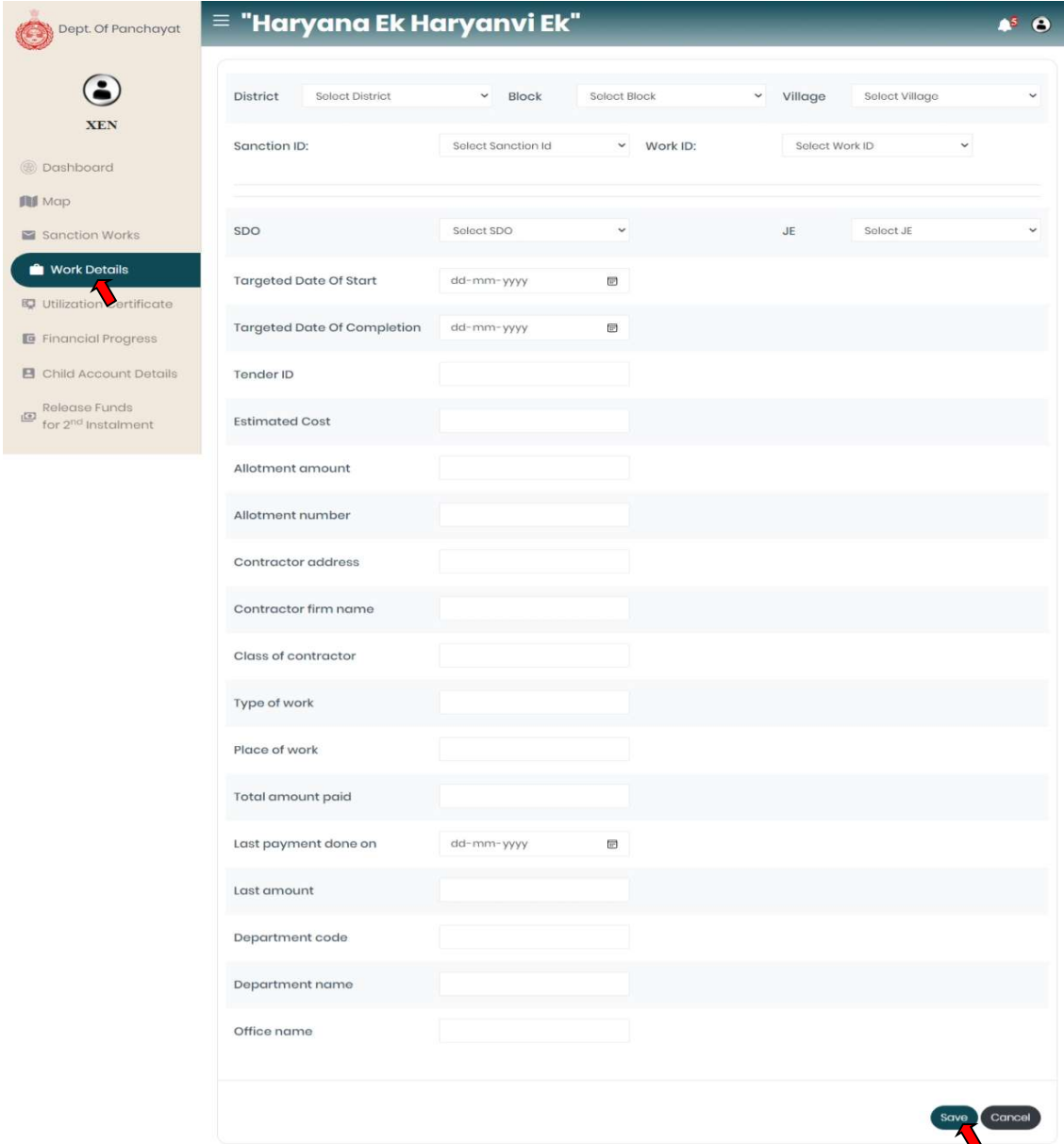

Dept. Of Panchayat

XEN

Dashboard

Map

Sanction Works

Work Details

Utilization Certificate

Financial Progress

Child Account Details

Release Funds for 2nd Instalment

"Haryana Ek Haryanvi Ek"

District: Select District Block: Select Block Village: Select Village

Sanction ID: Select Sanction Id Work ID: Select Work ID

SDO: Select SDO JE: Select JE

Targeted Date Of Start: dd-mm-yyyy

Targeted Date Of Completion: dd-mm-yyyy

Tender ID: [Text Field]

Estimated Cost: [Text Field]

Allotment amount: [Text Field]

Allotment number: [Text Field]

Contractor address: [Text Field]

Contractor firm name: [Text Field]

Class of contractor: [Text Field]

Type of work: [Text Field]

Place of work: [Text Field]

Total amount paid: [Text Field]

Last payment done on: dd-mm-yyyy

Last amount: [Text Field]

Department code: [Text Field]

Department name: [Text Field]

Office name: [Text Field]

Save Cancel

User Manual for Funds Disbursement Management System

3.3. Utilization Certificate:

Click on utilization certificate from side nav in the XEN login. XEN will fill Utilization Certification for the demand works and also check the physical status by clicking on view image.

XEN → Utilization Certificate

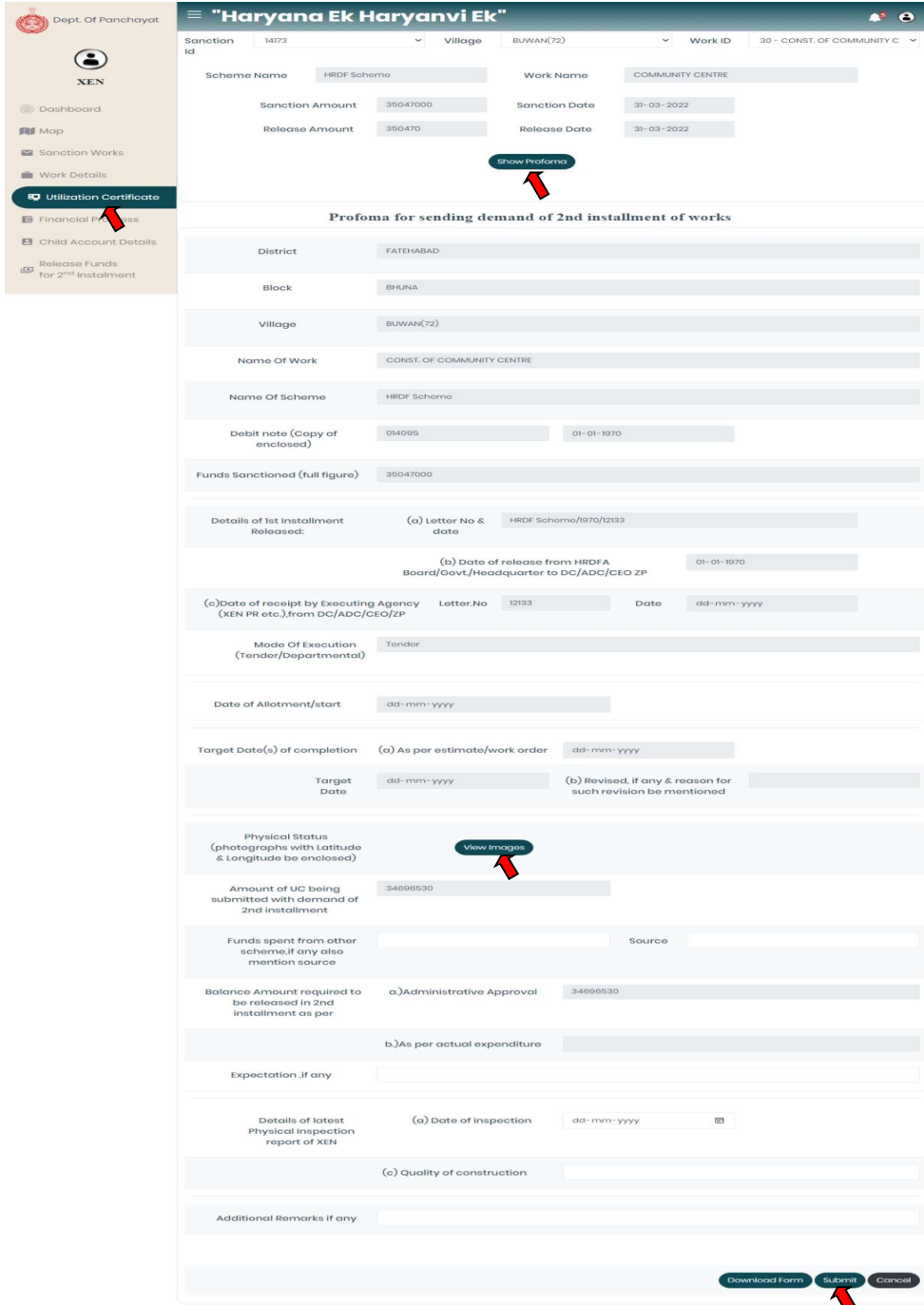

Dept. Of Panchayat

XEN

Dashboard

Map

Sanction Works

Work Details

Utilization Certificate

Financial Passes

Child Account Details

Release Funds for 2nd instalment

"Haryana Ek Haryanvi Ek"

Sanction Id: 14173 | Village: BUWAN(72) | Work ID: 30 - CONST. OF COMMUNITY C

Scheme Name: HRDF Scheme | Work Name: COMMUNITY CENTRE

Sanction Amount: 35047000 | Sanction Date: 31-03-2022

Release Amount: 350470 | Release Date: 31-03-2022

Show Profoma

Profoma for sending demand of 2nd installment of works

District: FATEHABAD

Block: BHUNA

Village: BUWAN(72)

Name Of Work: CONST. OF COMMUNITY CENTRE

Name Of Scheme: HRDF Scheme

Debit note (Copy of enclosed): 014095 | 01-01-1970

Funds Sanctioned (full figure): 35047000

Details of 1st Installment Released: (a) Letter No & date: HRDF Schema/1970/12133

(b) Date of release from HRDFA Board/Govt./Headquarter to DC/ADC/CEO ZP: 01-01-1970

(c) Date of receipt by Executing Agency (XEN PR etc.) from DC/ADC/CEO/ZP: Letter.No: 12133 | Date: dd-mm-yyyy

Mode Of Execution (Tender/Departmental): Tender

Date of Allotment/start: dd-mm-yyyy

Target Date(s) of completion: (a) As per estimate/work order: dd-mm-yyyy

Target Date: dd-mm-yyyy | (b) Revised, if any & reason for such revision be mentioned

Physical Status (photographs with Latitude & Longitude be enclosed): View Images

Amount of UC being submitted with demand of 2nd installment: 34696530

Funds spent from other scheme, if any also mention source: Source

Balance Amount required to be released in 2nd installment as per: a.) Administrative Approval: 34696530

b.) As per actual expenditure

Expectation, if any

Details of latest Physical inspection report of XEN: (a) Date of inspection: dd-mm-yyyy

(c) Quality of construction

Additional Remarks if any

Download Form | Submit | Cancel

User Manual for Funds Disbursement Management System

3.4. Financial Progress:

Click on financial progress from side nav in the XEN login. XEN will fill the financialise of vendor with all the deductions.

XEN → Financial Progress

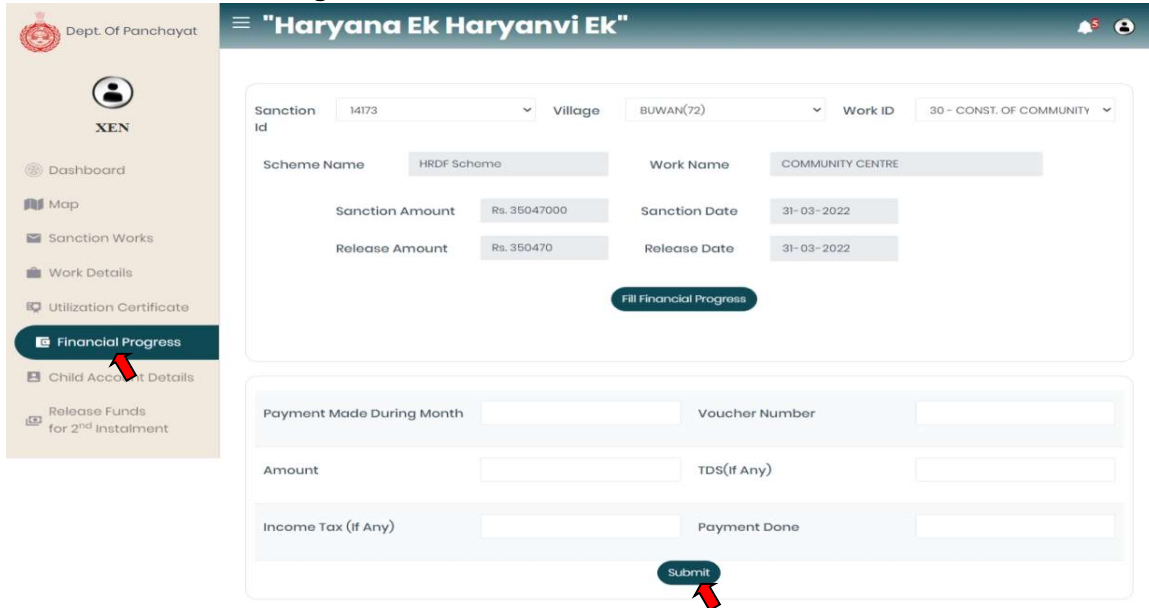

Dept. Of Panchayat

"Haryana Ek Haryanvi Ek"

Sanction Id: 14173 | Village: BUWAN(72) | Work ID: 30 - CONST. OF COMMUNITY

Scheme Name: HRDF Scheme | Work Name: COMMUNITY CENTRE

Sanction Amount: Rs. 35047000 | Sanction Date: 31-03-2022

Release Amount: Rs. 350470 | Release Date: 31-03-2022

Fill Financial Progress

Payment Made During Month: | Voucher Number:

Amount: | TDS(if Any):

Income Tax (if Any): | Payment Done:

Submit

3.5. Child Account Details:

Click on child account details from side nav in the XEN login. XEN will check own account details from here.

XEN → Child Account Details

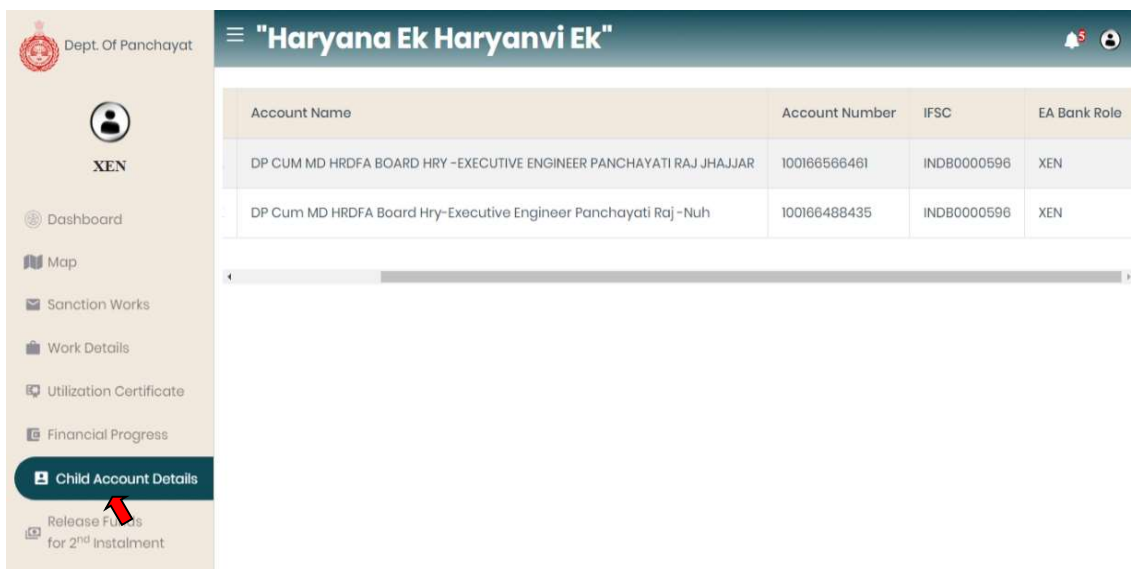

Dept. Of Panchayat

"Haryana Ek Haryanvi Ek"

Account Name	Account Number	IFSC	EA Bank Role
DP CUM MD HRDFA BOARD HRY - EXECUTIVE ENGINEER PANCHAYATI RAJ JHAJJAR	100166566461	INDB0000596	XEN
DP Cum MD HRDFA Board Hry-Executive Engineer Panchayati Raj -Nuh	100166488435	INDB0000596	XEN

User Manual for Funds Disbursement Management System

4. Physical Monitoring:

4.1. Alert Notification Pending:

- If XEN does not click on the bell icon, then a popup will be shown which will show “Alert Pending, please click on bell button!”.

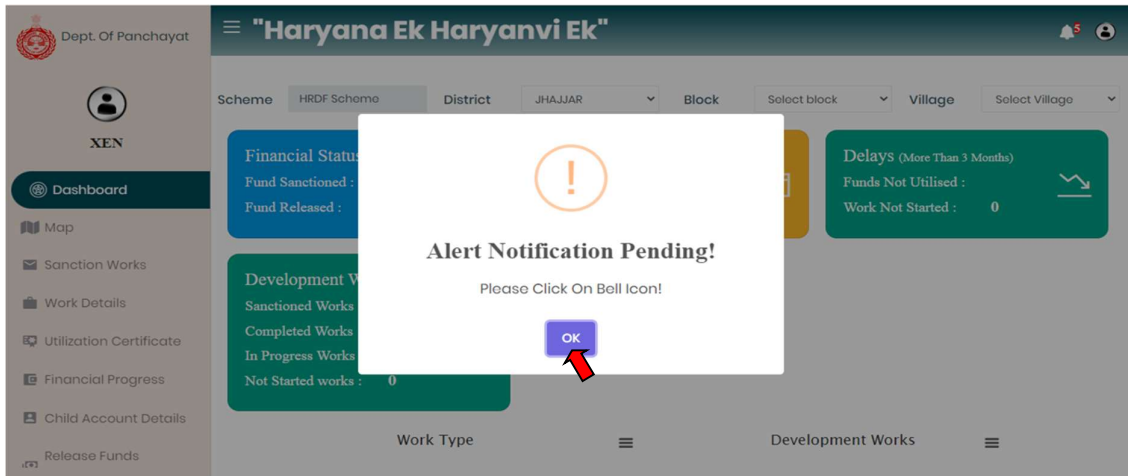

4.2. Inspection Report:

- Once tender/ work detail form is filled, alert module gets activated i.e., every work status which is started/ in-progress/ abandoned must be submitted by XEN.
- If JE/SDO/XEN does not upload inspection images on their defined time, then alert should be shown on web application dashboard, showing – “Submit Inspection Report through App”.
- The bell button is visible in the header which will show a table which will contain all the alerts for which work detail form is filled. XEN will fill the response i.e., started/ in-progress/ abandoned and remarks.

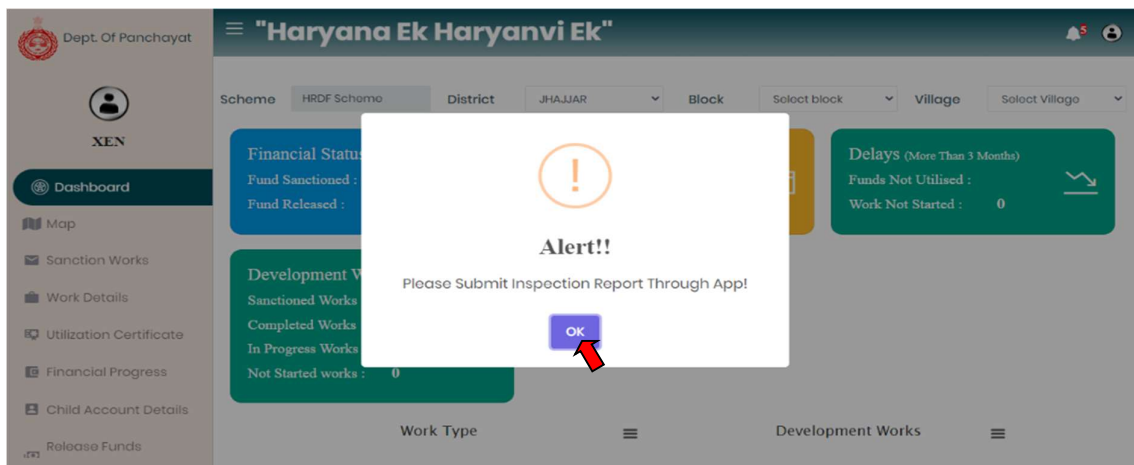

User Manual for Funds Disbursement Management System

- The bell button is visible on the header which will show a table which will contain all the alerts for which work detail form is filled. XEN will fill the response i.e., started/ in-progress/ abandoned and remarks.

Alert Module x

Sanction ID	Work Name	Village Name	In progress	Not Started	Abandoned	Remark
14196	CONST. OF COMMUNITY CENTRE	AGON(104)	<input type="radio"/>	<input type="radio"/>	<input type="radio"/>	
98424	nnnnnnn	AGON(104)	<input type="radio"/>	<input type="radio"/>	<input type="radio"/>	

5. Through Mobile Application:

5.1. In JE Login:

- When all the Sanction work will be visible in the JE login, then JE will be ready to go on the site.
- Once work is started, JE will get the authority to Upload Site photograph through mobile app by logging into his credentials.
- Once JE login then select the Sanction Id, Village ID, Work ID and Work Remark from the given dropdown.
- Then Scheme name, Sanction Amount and Release A mount automatically reflected on the basis of selected sanction id.
- JE will upload work status and select work reasons from the dropdown.
- Mobile App will also consist of Generate Inspection Report with remarks and upload the site image with upload button. Image will be uploaded with date, time, address & with latitude, longitude.
- Then submit the report by click on the Submit Report button.

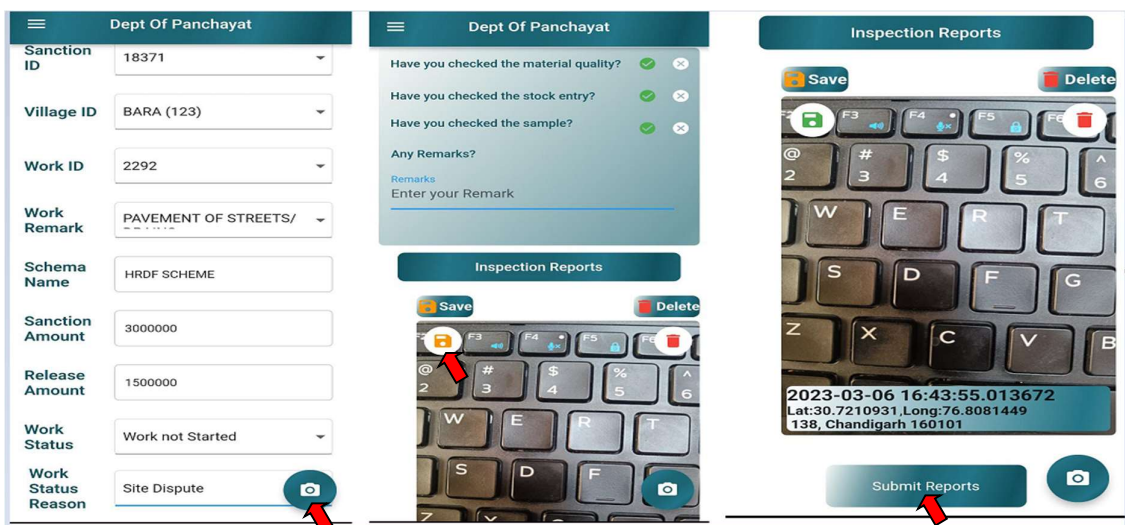

User Manual for Funds Disbursement Management System

5.2. In SDO Login:

These are the screens regarding JE inspection which is compared at SDO login and submitted by SDO.

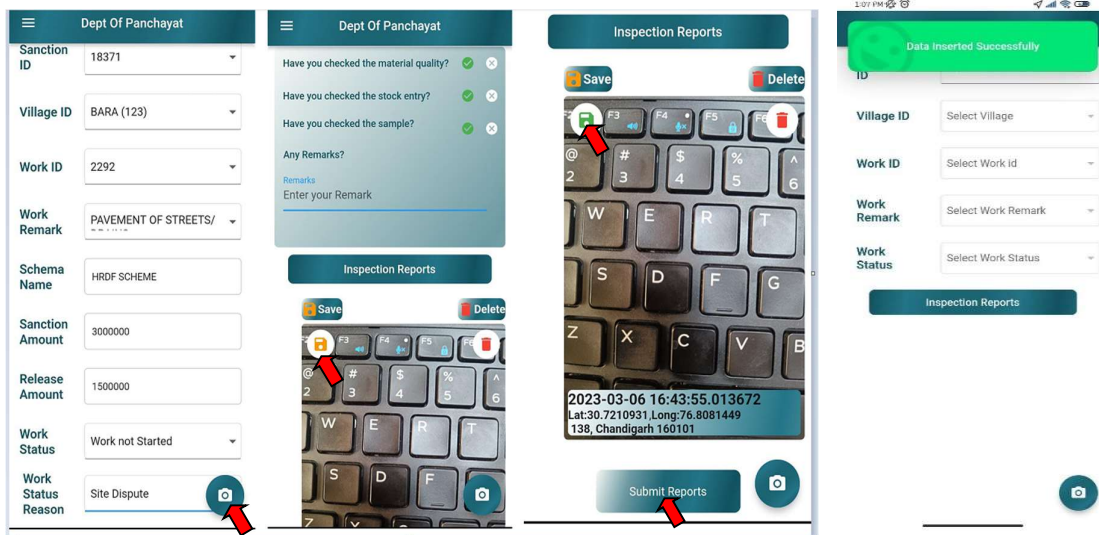

5.3. In XEN Login

After Submission of JE and SDO reports the file is moved to XEN for the comparison. If clicked image latitude and longitude is different then error will show (Distance is greater than 15 meters) and report is not submit.

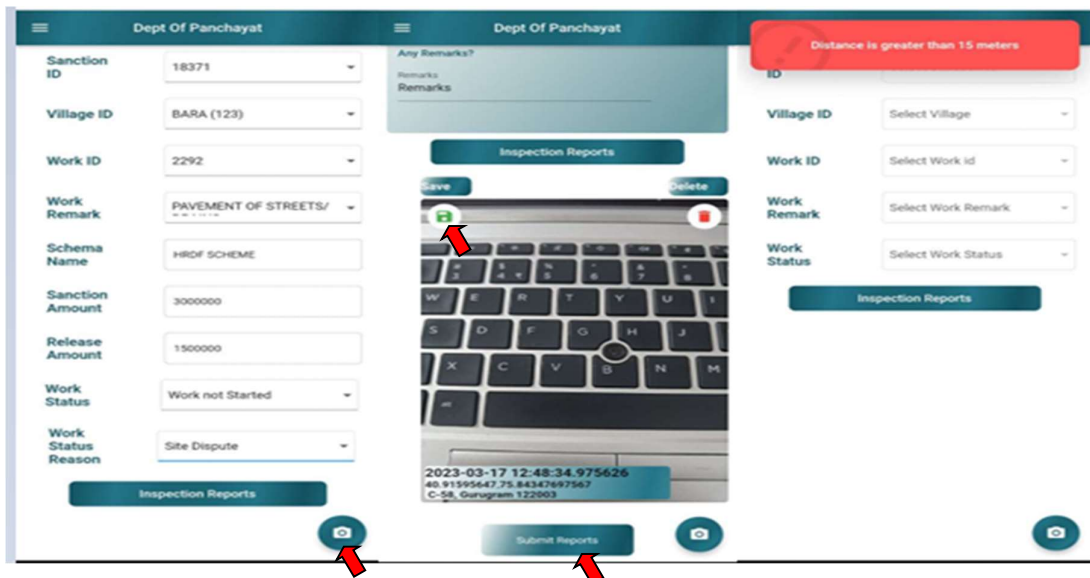

User Manual for Funds Disbursement Management System

6. Utilization Certificate:

- XEN can fill the utilization certificate form for the sanctioned amount < instalment installment amount for that particular work.
- The instalment display will be filled automatically for the fields that are already filled in the instalment and also click on the visual image for the physical position. XEN→Utilization Certificate
- When XEN submits this form, the data will be inserted and the workflow will start.

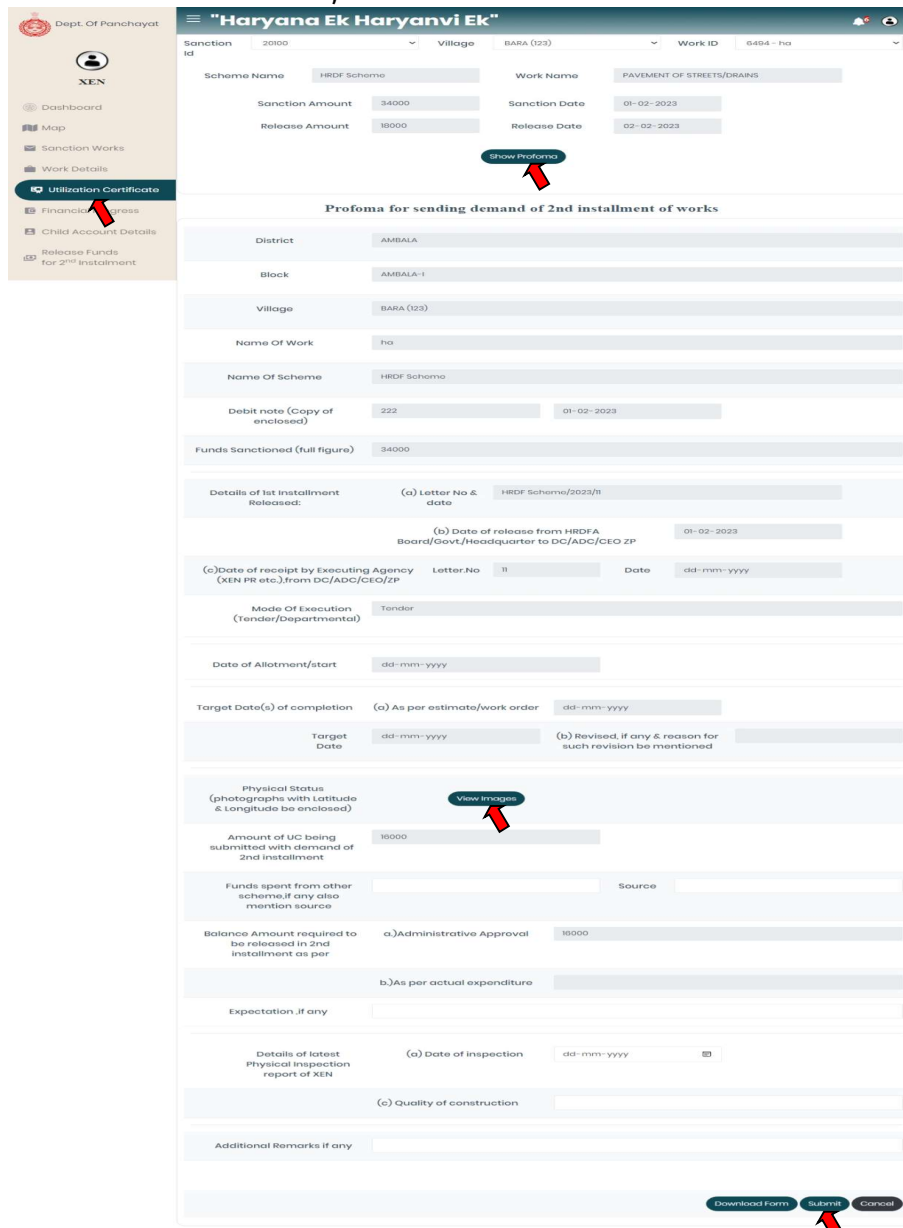

Dept. Of Panchayat
XEN

Dashboard
Map
Sanction Works
Work Details
Utilization Certificate
Financial Access
Child Account Details
Release Funds for 2nd Installment

"Haryana Ek Haryanvi Ek"

Sanction Id: 20100 | Village: BARA (123) | Work ID: 6494 - ha

Scheme Name: HRDF Scheme | Work Name: PAVEMENT OF STREETS/DRAINS

Sanction Amount: 34000 | Sanction Date: 01-02-2023
Release Amount: 18000 | Release Date: 02-02-2023

Show Profoma

Profoma for sending demand of 2nd installment of works

District: AMBALA
Block: AMBALA-1
Village: BARA (123)
Name Of Work: ha
Name Of Scheme: HRDF Scheme

Debit note (Copy of enclosed): 222 | 01-02-2023

Funds Sanctioned (full figure): 34000

Details of 1st installment Released:
(a) Letter No & date: HRDF Scheme/2023/11
(b) Date of release from HRDFA Board/Govt./Headquarter to DC/ADC/CEO ZP: 01-02-2023

(c) Date of receipt by Executing Agency (XEN PR etc.) from DC/ADC/CEO/ZP: Letter.No: 11 | Date: dd-mm-yyyy

Mode Of Execution (Tender/Departmental): Tender

Date of Allotment/start: dd-mm-yyyy

Target Date(s) of completion (a) As per estimate/work order: dd-mm-yyyy
Target Date: dd-mm-yyyy | (b) Revised, if any & reason for such revision be mentioned

Physical Status (photographs with Latitude & Longitude be enclosed): **View Images**

Amount of UC being submitted with demand of 2nd installment: 18000

Funds spent from other scheme, if any also mention source: Source

Balance Amount required to be released in 2nd installment as per:
a.) Administrative Approval: 18000
b.) As per actual expenditure:

Expectation, if any:

Details of latest Physical Inspection report of XEN:
(a) Date of inspection: dd-mm-yyyy
(c) Quality of construction:

Additional Remarks if any:

Download Form **Submit** **Cancel**

User Manual for Funds Disbursement Management System

7. Helpline Numbers:

7.1. IT Support Team:

S.No	Name	Support Type	Email ID	Phone	Support Timing	Days
1	Jagriti	Functional	jagriti.sood@austere.co.in	9459755823	9 AM to 11 AM & 2 P M to 4 PM	Mon to Fri
2	Priyanka	Functional	priyanka.yadav@austere.co.in	8076268650	9 AM to 11 AM & 2 P M to 4 PM	Mon to Fri
3	Akshat	Technical	akshat.sharma@austere.co.in	7357972911	9 AM to 11 AM & 2 P M to 4 PM	Mon to Fri
4	Manoj	Technical	manoj.joshi@austere.co.in	7060162561	9 AM to 11 AM & 2 P M to 4 PM	Mon to Fri

7.2. Bank Representatives:

S.No	Name	Support Type	Email ID	Phone	Support Timing	Days
1	Shilpa Sharma	Banking Representative	Shilpa.csharma@indusind.com	8728051888	9 AM to 11 AM & 2 P M to 4 PM	Mon to Fri
2	Gauri Duggal	Banking Representative	Gauri.duggal@indusind.com	7837668139	9 AM to 11 AM & 2 P M to 4 PM	Mon to Fri

THANKS FOR GIVING OPPORTUNITY

Corporate Office: Office no 301/2/3 A SQUARE Plot no 34 ADC , Sector 26 Pradhikaran , Pune,Maharastra ,INDIA 411044Branch

Office: C-74, LGF Suncity Sector-54, Golf Course Road Gurgaon, Haryana, INDIA

New Zealand: 136 Major DriveKelsonLower Hutt 5010NZE-mail :

sales@austere.co.in / rahul.tani@austere.co.in

Telephone : IND - +91-772 008 3881/2/3, IND : +91-982 256 4489, NZ - +64-224 142 932